

uniden

Service Manual



Model PC 33

**40-Channel AM Mobile
Citizens Band Radios**

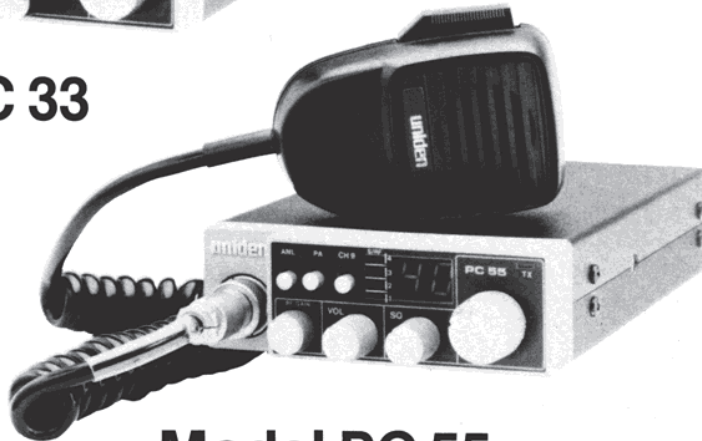

Model PC 55

uniden
CORPORATION OF AMERICA

PERSONAL COMMUNICATIONS GROUP
6345 Castleway Court • Indianapolis, IN 46250 • (317) 842-0280

© 1984

PC 33/PC 55

TABLE OF CONTENTS

	PAGE
SPECIFICATIONS	4
CIRCUIT DESCRIPTION	5-6
ALIGNMENT PROCEDURES	7-9
ALIGNMENT LAYOUT	10
PC 33 BLOCK DIAGRAM	11
PC 55 BLOCK DIAGRAM	12
PC 33 SCHEMATIC DIAGRAM	13-14
PC 55 SCHEMATIC DIAGRAM	15-16
PLL BLOCK DIAGRAM	17
WIRING DIAGRAMS	18-19
PARTS LAYOUTS	20-22
CHANNEL/FREQUENCY CHART	23
PLL PROGRAMMING CHART	24
PC 33 VOLTAGE CHARTS	25-26
PC 55 VOLTAGE CHARTS	27-28
SEMICONDUCTOR PINOUTS	29
PARTS LIST	30-37

PC 33/PC 55 SPECIFICATIONS

GENERAL

Channels	40
Frequency Range	26.965 to 27.405
Frequency Control	Phase Lock Loop (PLL) synthesizer
Frequency Tolerance	0.005%
Operating Temperature Range	- 30°C to + 50°C
Microphone	Plug-in type; dynamic
Input Voltage	13.8V DC nominal (positive or negative ground)
Current Drain	Transmit: AM full mod., 1.5A (maximum) Receive: Squelched, 0.25A; full audio output 1.0A (nominal)
Size (WxDxH)	6" x 6" x 1.5"
Weight	2.4 pounds
Antenna Connector	UHF, SO-239
LED Meter	Indicates relative power output and received signal strength.

TRANSMITTER

Power Output	4 watts
Modulation	Class B amplitude modulation
Frequency Response	300-3000 Hz
Output Impedance	50 ohms, unbalanced

RECEIVER

Sensitivity	Less than 1uV for 10 db (S + N)/N
Selectivity	6 db @ 7 KHz, 60 db @ 10 KHz
Image Rejection	- 80 db, typical
Adjacent Channel Rejection	- 60 db, typical
IF Frequencies	Double Conversion 1st: 10.695 MHz 2nd: 455 KHz
Automatic Gain Control (AGC)	Less than 10 db change in audio output for inputs from 10 to 10,000 microvolts
Squelch	Adjustable; threshold less than 1uV
Audio Output Power	4 watts
Frequency Response	300-3000 Hz
Distortion	Less than 7% @ 3 watts @ 1000 Hz
Built-in Speaker	16 ohms, round
External Speaker (not supplied)	8 ohms; disables internal speaker when connected

PA SYSTEM (PC 55 only)

Power Output	4 watts into external speaker
External Speaker (not supplied)	8 ohms; when PA-CB switch is in PA, the PA speaker also monitors the receiver; separate jack provided

UNIDEN MODELS PC 33 AND PC 55 CIRCUIT DESCRIPTION

PLL FREQUENCY SYNTHESIZER

The receive and transmit frequencies of these radios are controlled by the synthesizer. This synthesizer supplies the signal to the first mixer of the receiver TR2 and to the transmit mixer IC2. This frequency (16.725 to 17.165 MHz in Tx mode and 16.270 to 16.710 MHz in Rx mode) is generated by a voltage-controlled-oscillator (VCO) made up of TR10, D10 and L13. This oscillator runs at the above frequencies, but is closely controlled by IC1. This IC is known as the PLL IC. Transistor TR9 is a crystal oscillator controlled by a 10.240 MHz crystal X1. This 10.240 MHz signal is used by the PLL IC as a reference frequency. This 10 MHz reference signal is divided internally by a factor of 1048 to derive a frequency of 5.000 KHz. A signal from the VCO also is sent to IC1 and is divided internally by some N number to derive 5.000 KHz. This N number is chosen by the setting of the channel selector switch (see frequency chart for N numbers). These two 5 KHz signals are compared by a phase detector in order to determine which way to correct the VCO frequency. The phase detector voltage is sent to a low-pass-filter and then back to the VCO and Varactor diode D10. This system insures that the VCO frequency remains stable. If, for some reason, the VCO runs at some incorrect frequency and is not corrected by the PLL IC within a certain time, the sample frequency (VCO divided by N) will no longer be 5.0 KHz. This error is detected by the PLL (IC1), and a signal is sent from pin 4 of IC1 to disable the transmitter (TR8) and the receiver (D5, TR1, TR2 and TR3). This insures that no signal will be transmitted or received on an illegal or invalid frequency. Before the VCO signal is used by the receiver or transmitter, it is buffered by the amplifier of TR11.

RECEIVER

Signals from the antenna are sent to the receiver RF amplifier TR1 through transformer L1. This 27 MHz signal is mixed with the 16 MHz signal from the synthesizer by L2 and TR2. The difference of the RF signal and the VCO signal is 10.695 MHz and is tuned by crystal filter FT1 to become the first IF frequency. The signal from TR9 and the 10.695 MHz signal is mixed, and the difference of the two (455 KHz) is tuned by ceramic filter FT2. This second IF frequency is amplified by TR4 and TR5 and tuned further by L5. This IF signal is demodulated by diode D5 and then sent to an audio pre-amp, TR6. A limiter (ANL) diode (D6) can be switched in and out by the ANL switch in order to limit impulse noise. VR501 changes the signal level sent to the audio power amp IC501 and is used as a volume control. Transistor TR7 is biased by VR552 and R36 in order to give variable squelch control. In the squelched condition, TR7 is on, which shuts TR6 off. When an audio signal of sufficient strength is received, the base of TR7 is brought lower, and it will turn off. This removes the ground from TR6 and allows audio to be heard from the speaker. Diode D4 rectifies a portion of the IF signal in order to measure the relative strength of the received signal. This voltage is sent to IC551 to be displayed by the LED bar display.

TRANSMITTER

In the transmit mode, transistor TR12 supplies VCO to the transmitter and switches the PLL IC into the transmit mode. The VCO signal is sent to a frequency mixer IC2 in order to be mixed with the 10.240 MHz signal from TR9. The 27 MHz component is tuned by a band-pass filter made of L14, L15 and L12. This signal now is used as the carrier frequency and is amplified by TR8. Microphone audio is amplified by TR13 and applied to the audio power amp IC501. Transformer T1 applies amplitude modulation to the collector of final amplifier TR501. This transmitter is driven by a driver stage of TR502. A portion of the modulation voltage is detected by diode D13 and is amplified by TR15. As the modulation increases, TR15 causes TR14 to limit the input to the mic amp TR13. This Automatic Modulation Control (AMC) circuit keeps the modulation from exceeding 100%. The AM signal is filtered by L8, L7 and L6 and sent to the antenna. Diode D7 samples the transmitter power from a tuned strip and rectifies and filters it into a DC voltage proportional to transmitter strength. This is displayed by IC551, and its bar display is an indication of transmitter strength.

ALIGNMENT OF RECEIVER

1. Test Equipment Required

Oscilloscope (50 MHz) DC Power Supply RF Signal Generator
AC Voltmeter 8 ohm Load

2. Alignment Procedure

STEP	PRESET TO	ADJUSTMENT	REMARKS
1	VOL: Max. SQ.: Min. CH: 19 ANL: OFF	L5, L4, L2 (L3 on 55)	Connect SSG to J501 and connect AC Voltmeter to J3. Adjust coils for maximum reading on AC voltmeter.
2	Same as Step 1	VR1	Adjust VR1 so that "4" of the LED Signal Meter when SSG level set to 600uV.
3	Same as Step 1 except SQ: MAX.	VR2	Set the level of SSG to 2000uV. Adjust semi-fixed resistor so that the squelch just breaks.

3. Test Equipment Connection

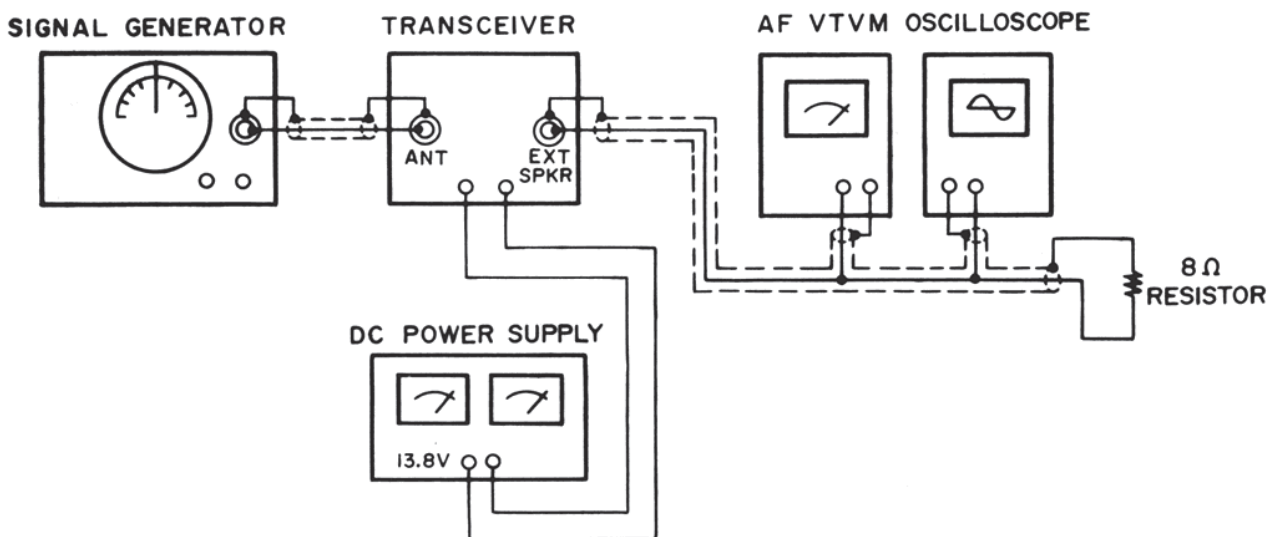

ALIGNMENT OF TRANSMITTER

1. Test Equipment Required

Oscilloscope (50 MHz)	DC Power Supply	AC Voltmeter
RF Power Meter	Frequency Counter	Deviation Meter
50 ohm Load	Audio Oscillator	

2. Alignment Procedure

STEP	PRESET TO	ADJUSTMENT	REMARKS
1	NO Modulation CH: 19 Mode: Tx	L12, L14 and L15	Connect Oscilloscope to TP-3 (R46). Adjust for maximum reading on Oscilloscope.
2	Same as Step 1	L11	Connect RF Power Meter to ANT Jack (J501). Adjust for maximum reading on RF Power Meter.
3	Same as Step 1	L8 and VR3	Adjust VR3 so that "3" LED just lights when L8 is set for 3.6W.
4	Same as Step 1	L8	Adjust for 4.0W on RF power meter.

3. Test Equipment Connection

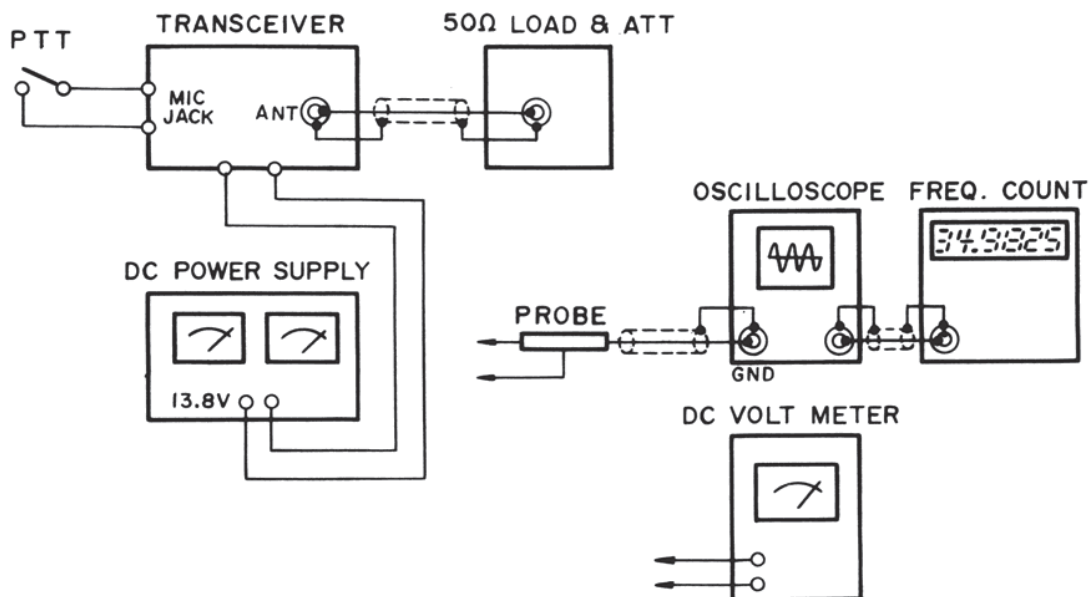

ALIGNMENT OF CARRIER OSCILLATOR

1. Test Equipment Required

Oscilloscope (50MHz) DC Power Supply DC Voltmeter
Frequency Counter

2. Alignment Procedure

STEP	PRESET TO	ADJUSTMENT	REMARKS
1	CH: 40 Mode: TX NO Modulation	L13	Connect DC Voltmeter to TP-1 (R62). Adjust for $4.0V \pm 0.1V$ on DC Voltmeter.

3. Test Equipment Connection

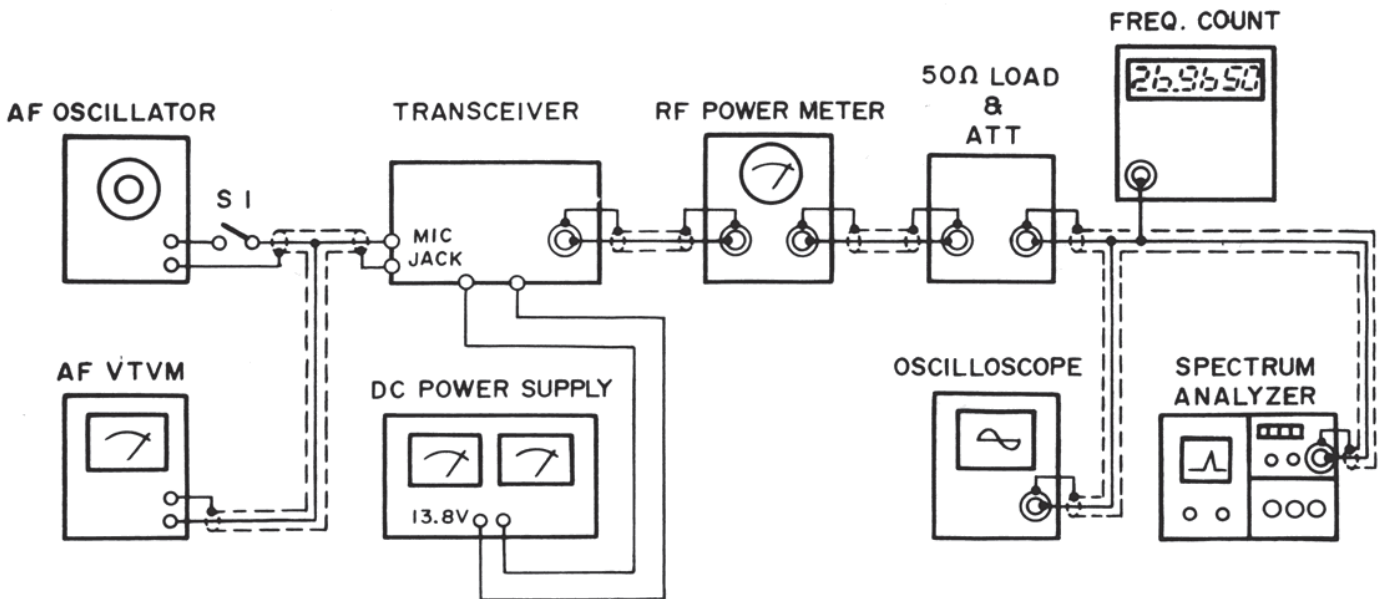

ALIGNMENT LAYOUT

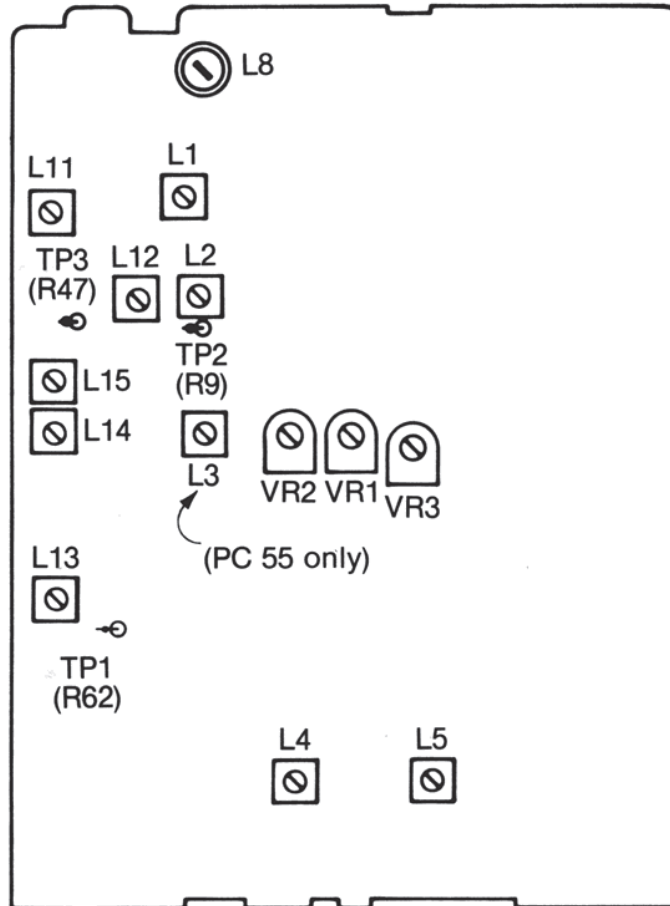

PC 33 BLOCK DIAGRAM

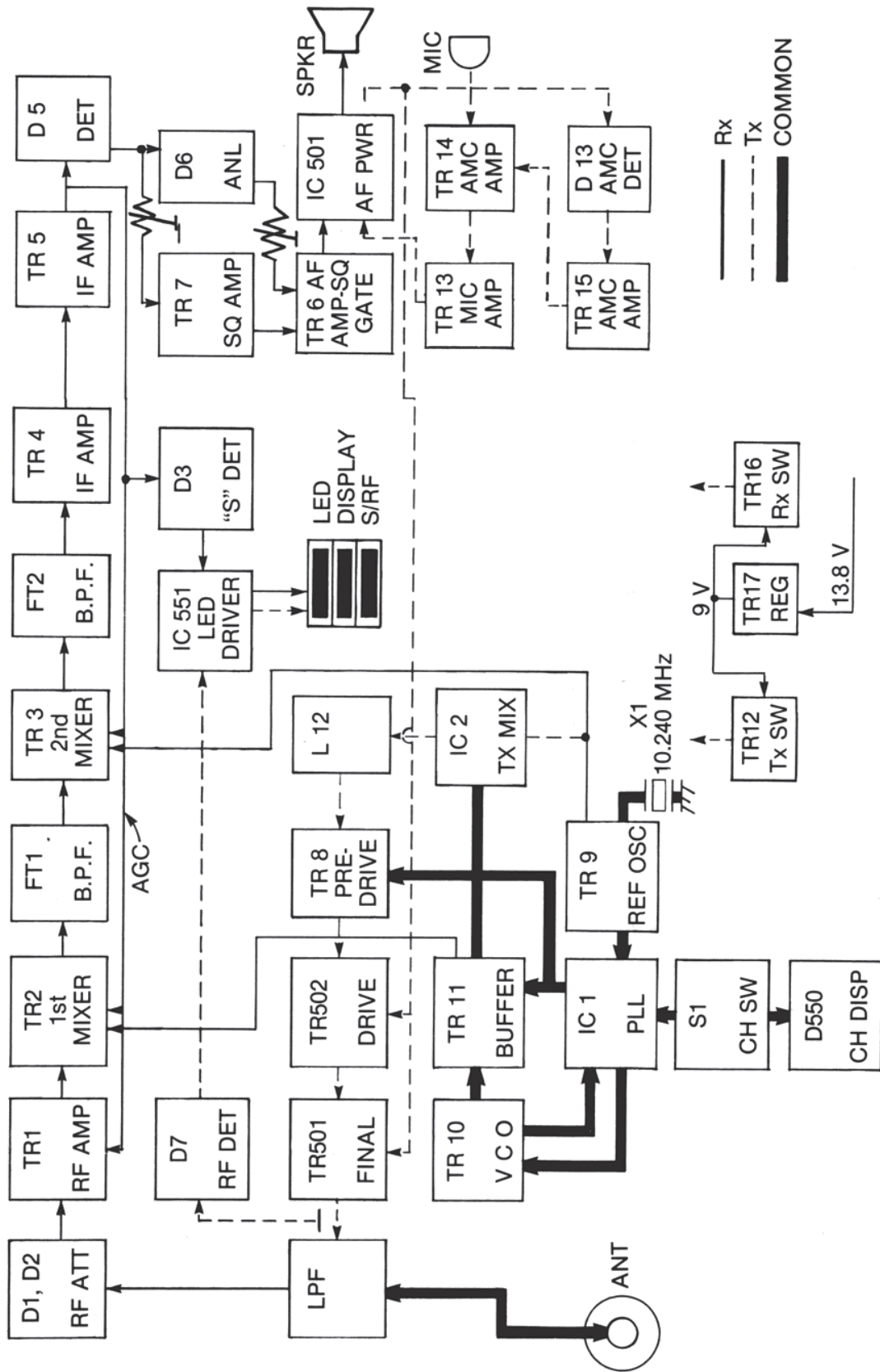

PC 55 BLOCK DIAGRAM

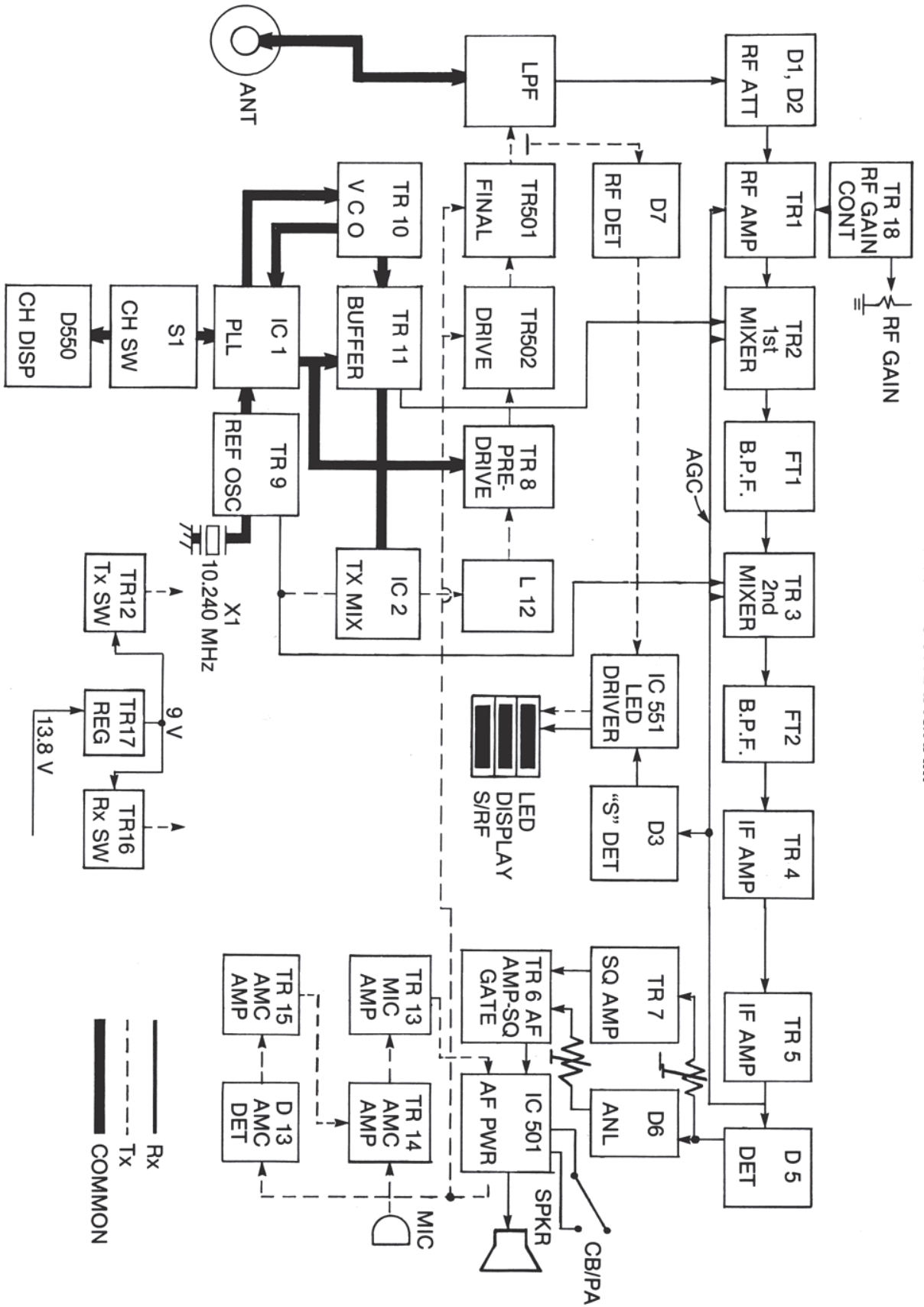

PLL BLOCK DIAGRAM (IC 1)

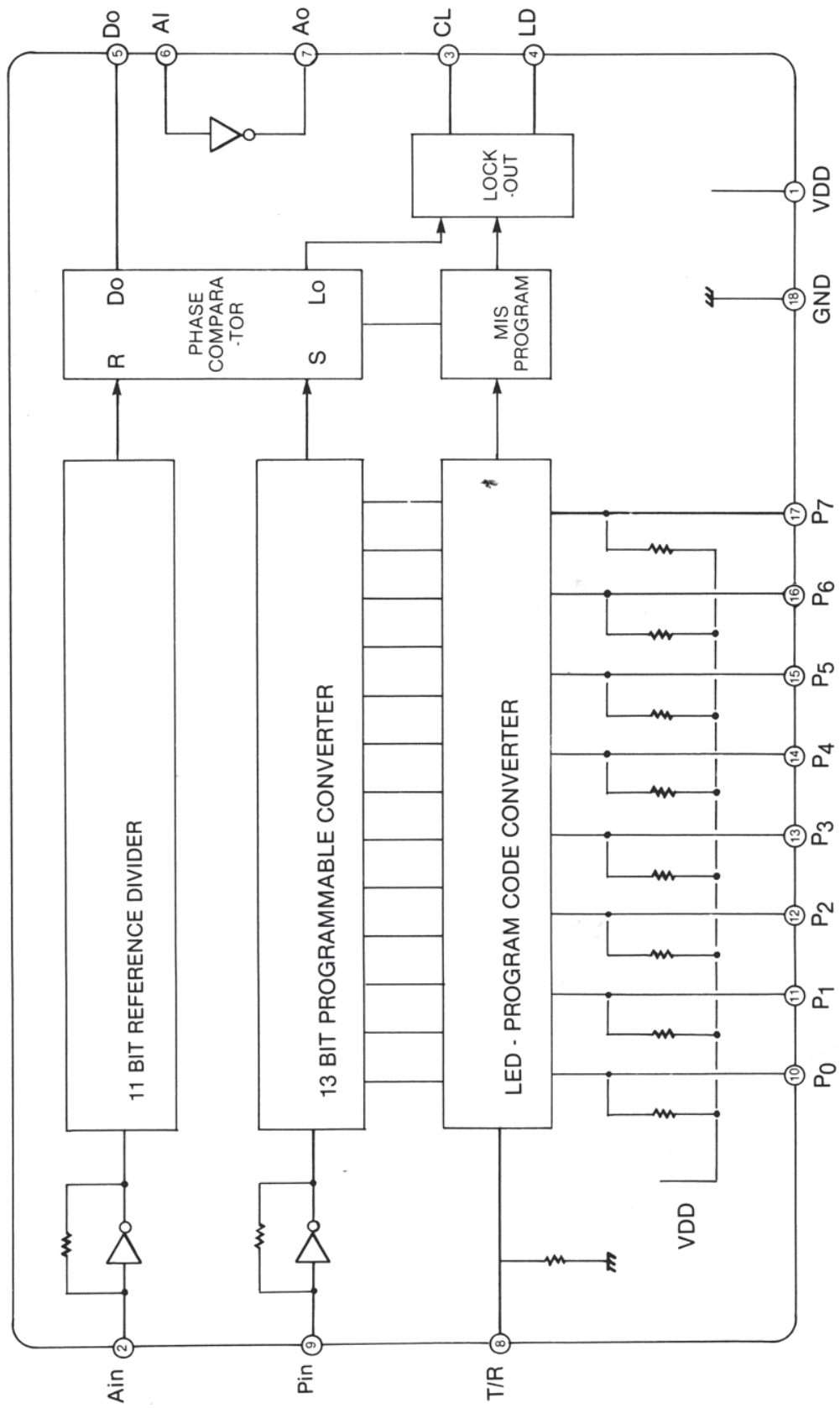

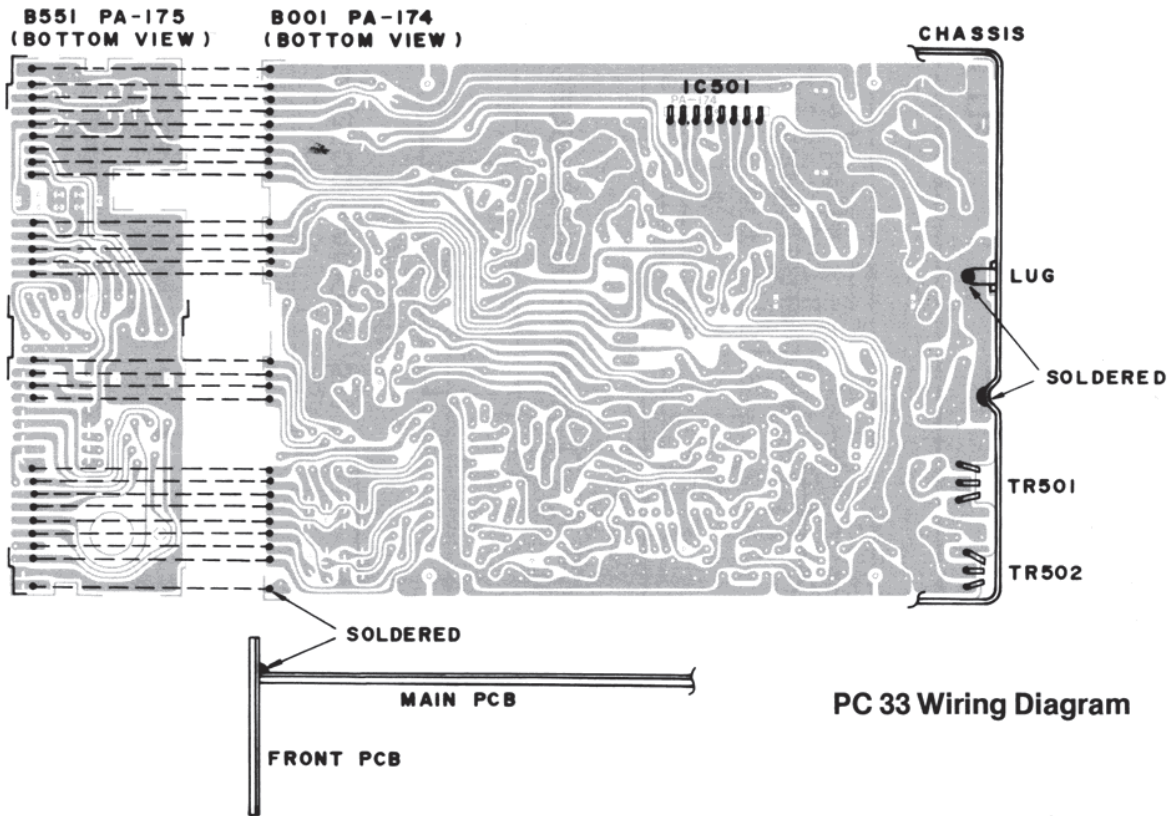
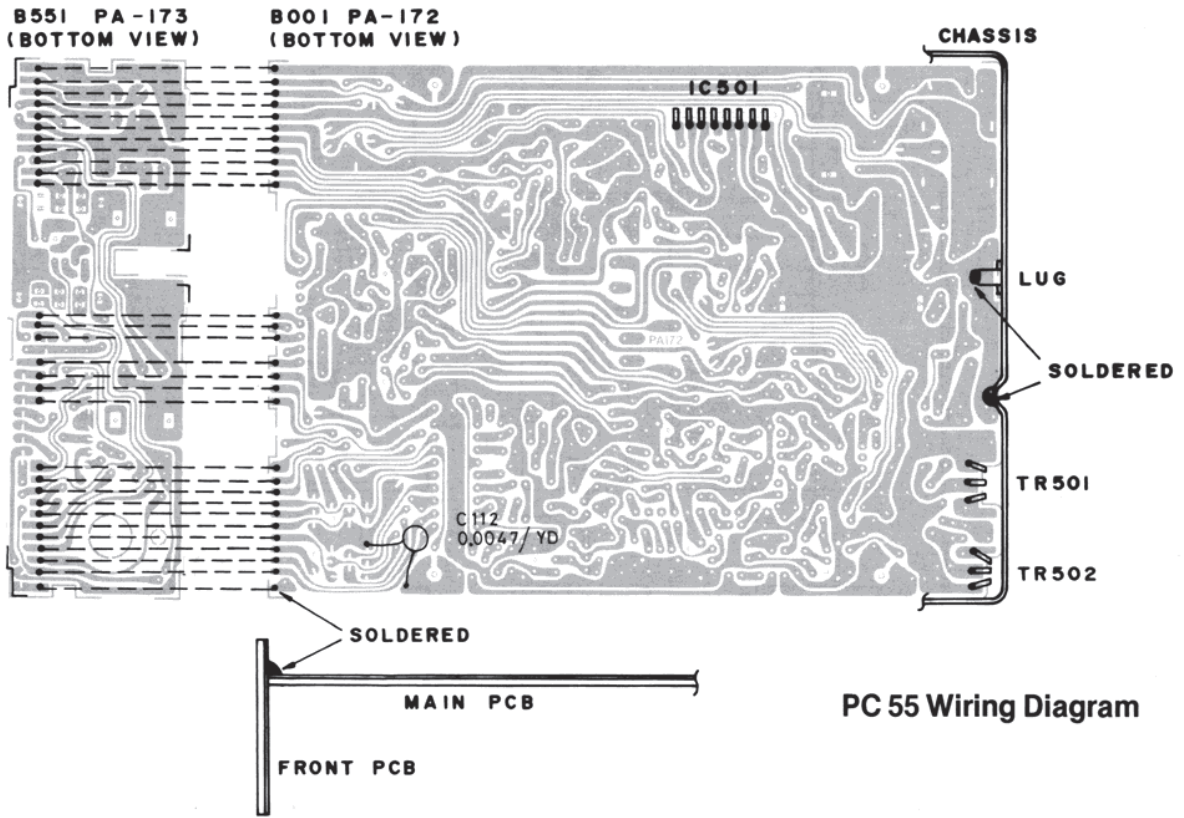

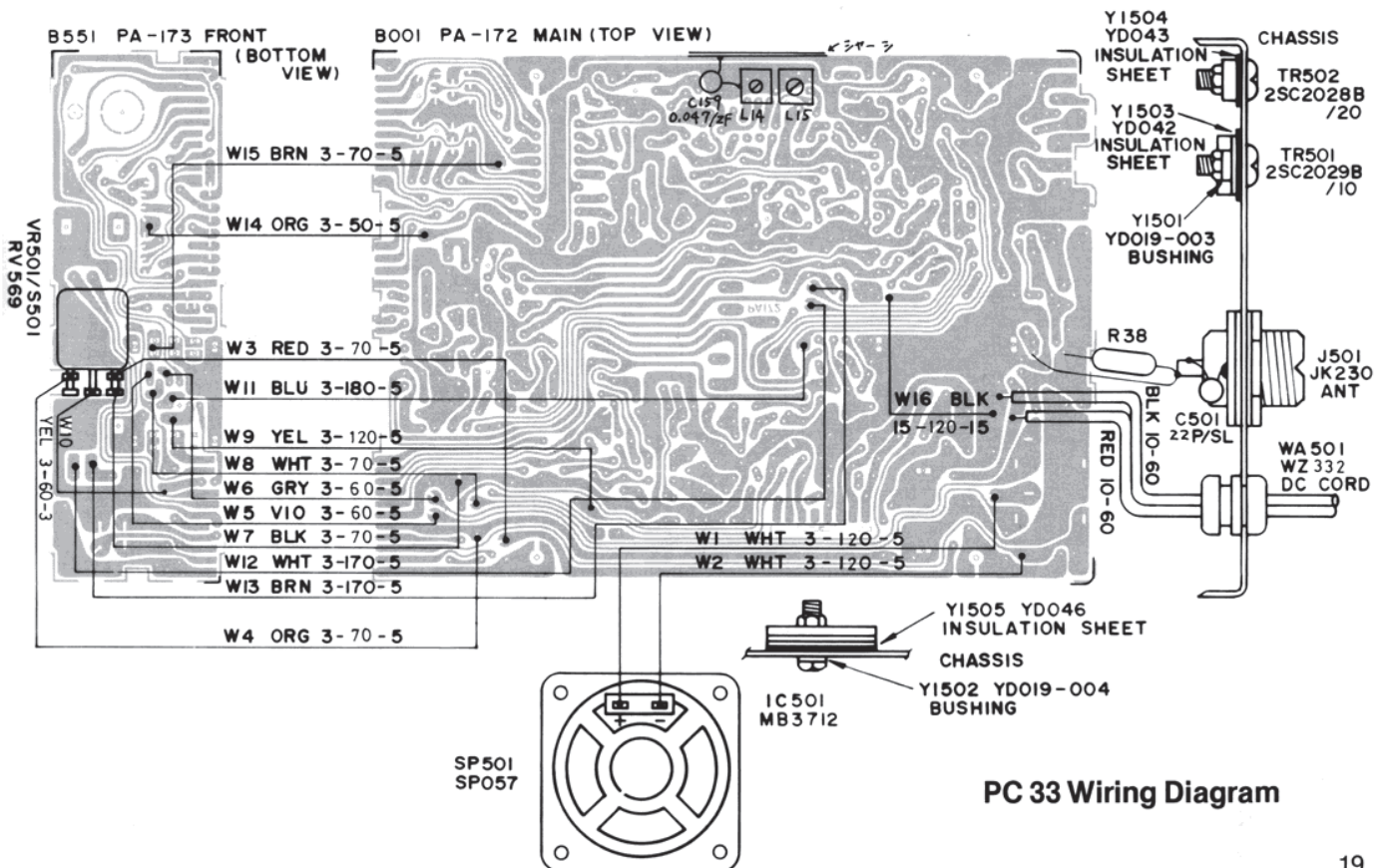
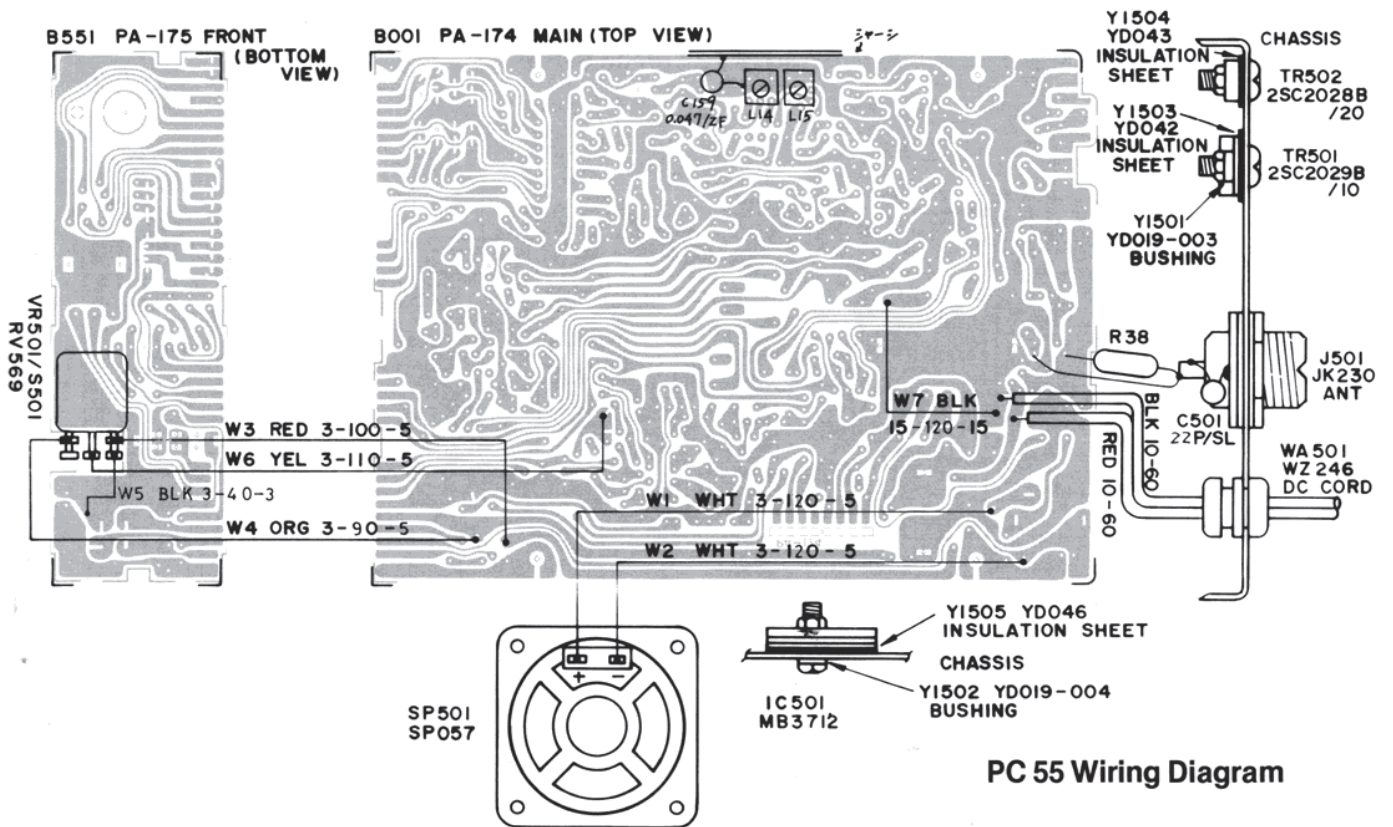

PC 33 Parts Layout

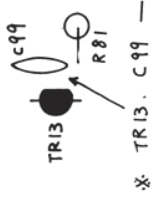

* TR13, C99 -

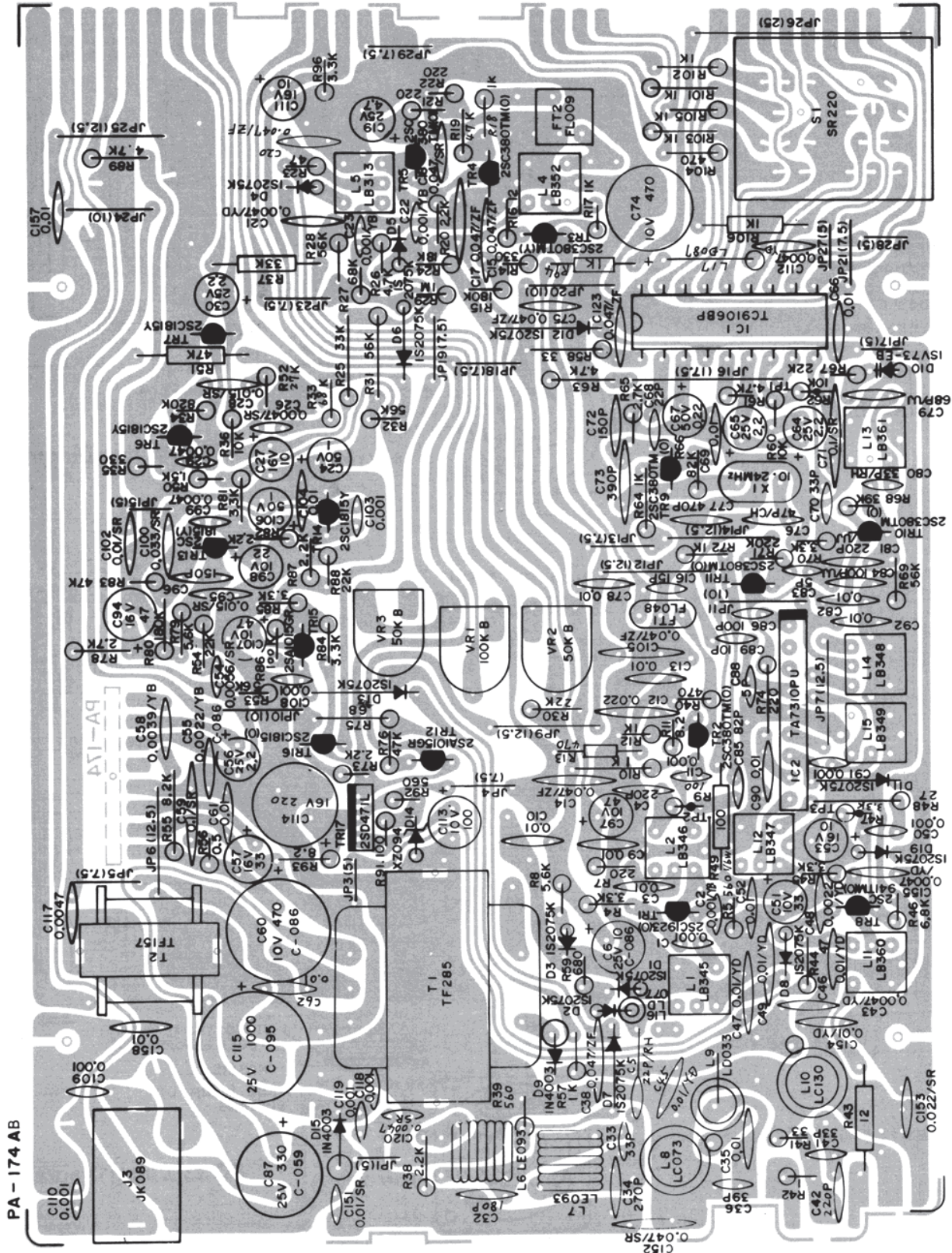

PC 55 Parts Layout

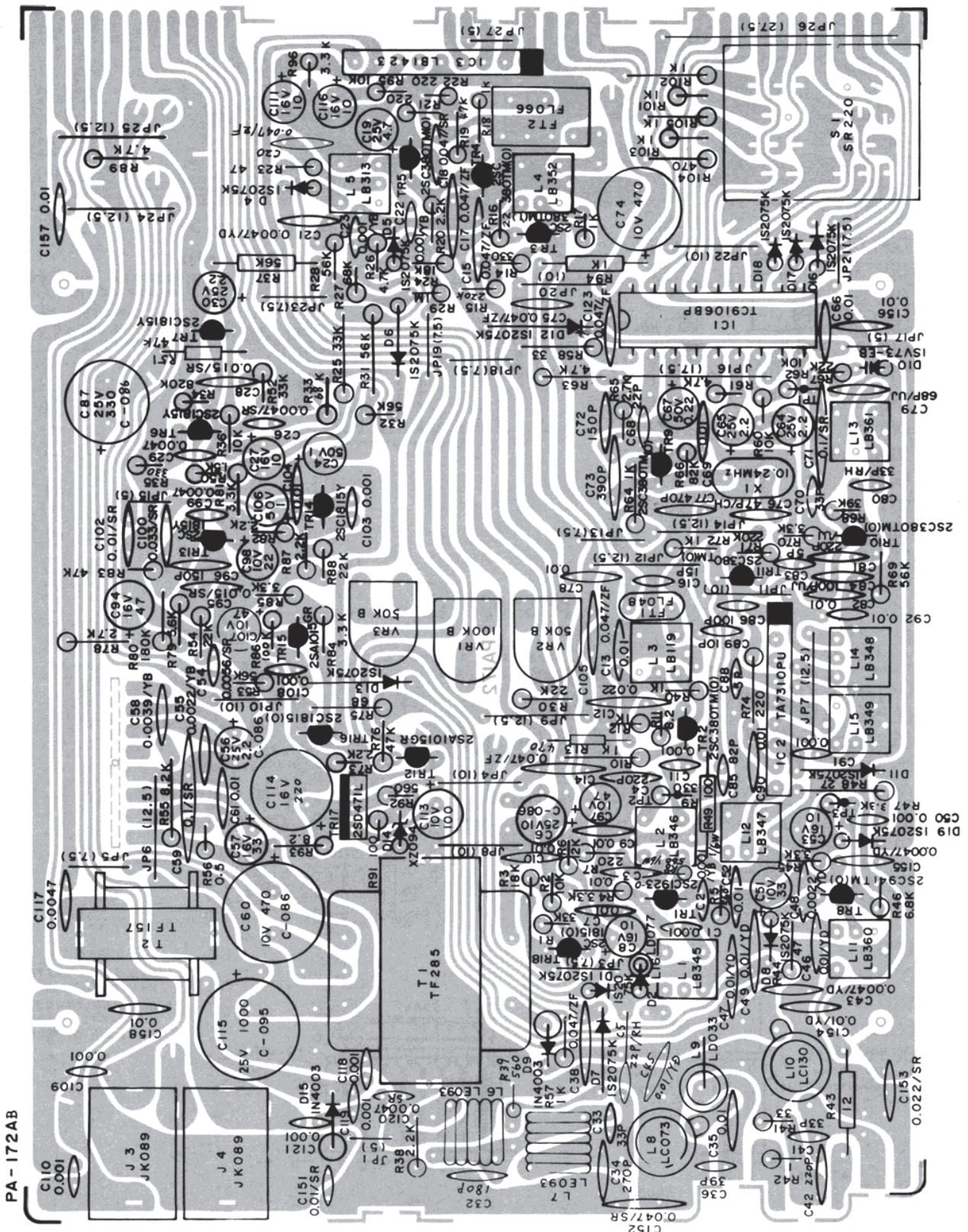

PC 33 Parts Layout

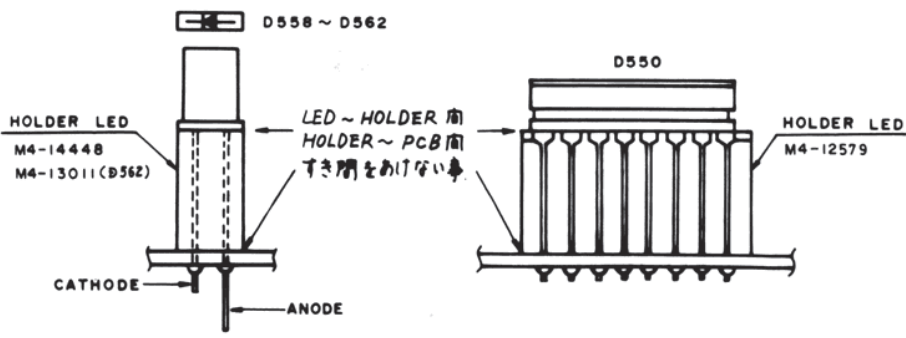
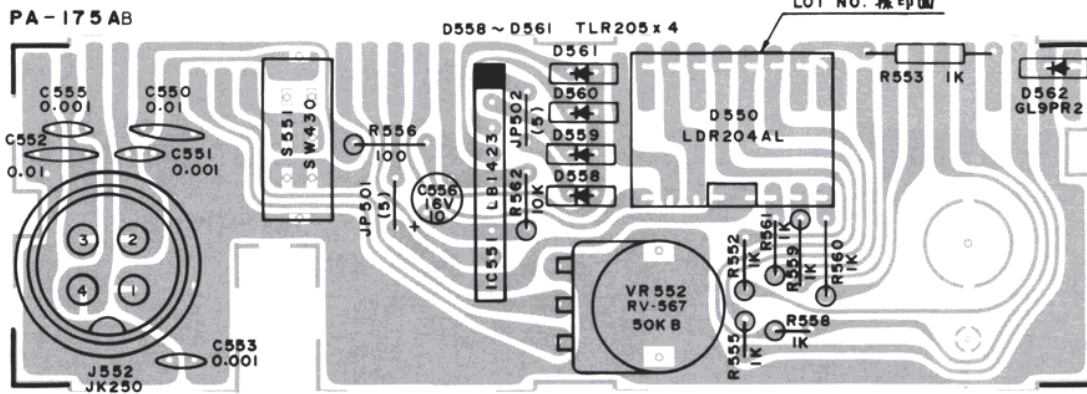

NOTE:

1. RESISTOR WATTAGES ARE 1/8W UNLESS OTHERWISE NOTED.
2. ALL CAPACITORS TEMPERATURE CHARACTERISTICS ARE YF UNLESS OTHERWISE NOTED

PC 55 Parts Layout

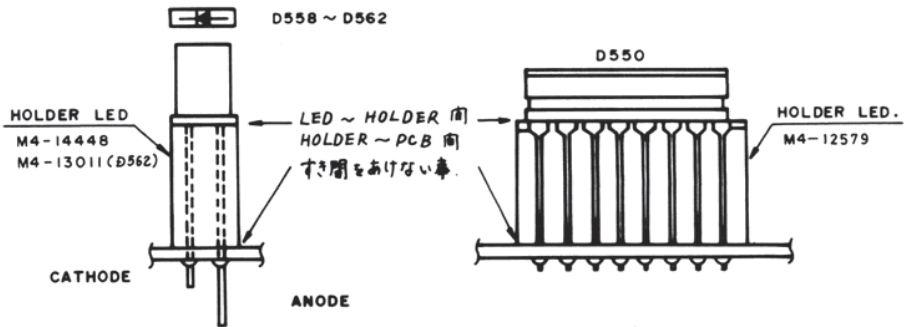
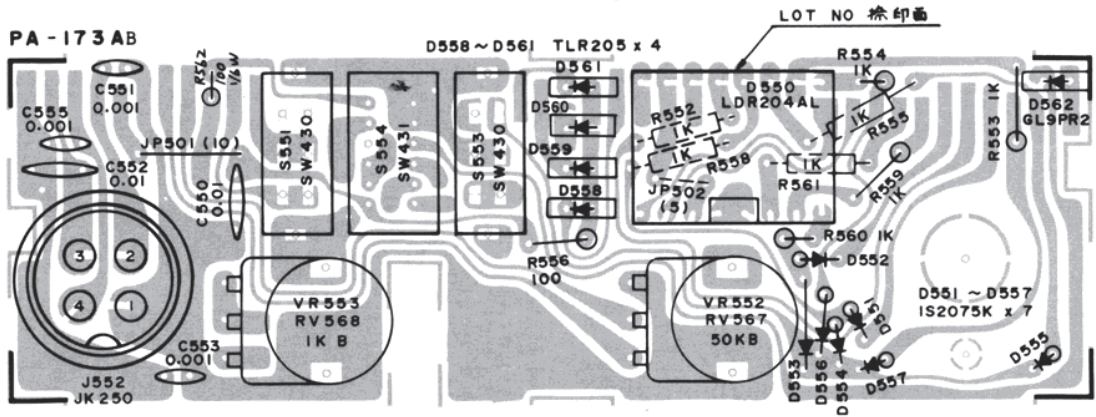

NOTES:

1. RESISTOR WATTAGES ARE 1/8W UNLESS OTHERWISE NOTED.
2. ALL CAPACITORS TEMPERATURE CHARACTERISTICS ARE YF UNLESS OTHERWISE NOTED

FREQUENCY CHART OF FVCO AND DIVIDE RATIO N

ANTENNA FREQUENCY (MHz)	CHANNEL NUMBER	FOR TRANSMIT (R/T = H)		FOR RECEIVE (R/T = L)		VCO FREQUENCY (MHz)
		DIVIDE RATIO (N)	VCO FREQUENCY (MHz)	DIVIDE RATIO (N)		
26.965	1	3,345	16.725	3,254		16.270
26.975	2	3,347	16.735	3,256		16.280
26.985	3	3,349	16.745	3,258		16.290
27.005	4	3,353	16.765	3,262		16.310
27.015	5	3,355	16.775	3,264		16.320
27.025	6	3,357	16.785	3,266		16.330
27.035	7	3,359	16.795	3,268		16.340
27.055	8	3,363	16.815	3,272		16.360
27.065	9	3,365	16.825	3,274		16.370
27.075	10	3,367	16.835	3,276		16.380
27.085	11	3,369	16.845	3,278		16.390
27.105	12	3,373	16.865	3,282		16.410
27.115	13	3,375	16.875	3,284		16.420
27.125	14	3,377	16.885	3,286		16.430
27.135	15	3,379	16.895	3,288		16.440
27.155	16	3,383	16.915	3,292		16.460
27.165	17	3,385	16.925	3,294		16.470
27.175	18	3,387	16.935	3,296		16.480
27.185	19	3,389	16.945	3,298		16.490
27.205	20	3,393	16.965	3,302		16.510
27.215	21	3,395	16.975	3,304		16.520
27.225	22	3,397	16.985	3,305		16.530
27.255	23	3,403	17.015	3,312		16.560
27.235	24	3,399	16.995	3,308		16.540
27.245	25	3,401	17.005	3,310		16.550
27.265	26	3,405	17.025	3,314		16.570
27.275	27	3,407	17.035	3,316		16.580
27.285	28	3,409	17.045	3,318		16.590
27.295	29	3,411	17.055	3,320		16.600
27.305	30	3,413	17.065	3,322		16.610
27.315	31	3,415	17.075	3,324		16.620
27.325	32	3,417	17.085	3,326		16.630
27.335	33	3,419	17.095	3,328		16.640
27.345	34	3,421	17.105	3,330		16.650
27.355	35	3,423	17.115	3,332		16.660
27.365	36	3,425	17.125	3,334		16.670
27.375	37	3,427	17.135	3,336		16.680
27.385	38	3,429	17.145	3,338		16.690
27.395	39	3,431	17.155	3,340		16.700
27.405	40	3,433	17.165	3,342		16.710

PLL PROGRAMMING CHART

CHANNEL NUMBER	PROGRAM INPUT DATA								
	Pin #	10	11	12	13	14	15	16	17
1		H	H	H	H	H	H	H	H
2		H	L	L	L	L	H	H	H
3		H	L	L	H	L	H	H	H
4		L	H	L	H	H	H	H	H
5		L	L	L	H	L	H	H	H
6		L	H	L	L	L	H	H	H
7		H	L	H	H	H	H	H	H
8		L	L	L	L	L	H	H	H
9		L	L	L	H	H	H	H	H
10		L	L	H	L	L	L	H	H
11		H	H	H	H	H	L	H	H
12		H	L	L	L	L	L	H	H
13		H	L	L	H	L	L	H	H
14		L	H	L	H	H	L	H	H
15		L	L	L	H	L	L	H	H
16		L	H	L	L	L	L	H	H
17		H	L	H	H	H	L	H	H
18		L	L	L	L	L	L	H	H
19		L	L	L	H	H	L	H	H
20		L	L	H	L	L	H	L	H
21		H	H	H	H	H	H	L	H
22		H	L	L	L	L	H	L	H
23		H	L	L	H	L	H	L	H
24		L	H	L	H	H	H	L	H
25		L	L	L	H	L	H	L	H
26		L	H	L	L	L	H	L	H
27		H	L	H	H	H	H	L	H
28		L	L	L	L	L	H	L	H
29		L	L	L	H	H	H	L	H
30		L	L	H	L	L	L	L	H
31		H	H	H	H	H	L	L	H
32		H	L	L	L	L	L	L	H
33		H	L	L	H	L	L	L	H
34		L	H	L	H	H	L	L	H
35		L	L	L	H	L	L	L	H
36		L	H	L	L	L	L	L	H
37		H	L	H	H	H	L	L	H
38		L	L	L	L	L	L	L	H
39		L	L	L	H	H	L	L	H
40		L	L	H	L	L	L	H	L

PC 33 VOLTAGE CHART

TR NO.		RX			TX		
		B	E	C	B	E	C
1	RF AMP	1.4	0.6	6.9	0.5	0	1.0
2	1st Mix	1.6	0.9	11.8	0.5	0	12.7
3	2nd Mix	0.6	0	7.5	0.3	0	1.0
4	IF AMP	0.7	0	2.2	0.2	0	1.0
5	IF AMP	2.2	1.5	12.2	1.0	0.4	12.6
6	OFF	1.0	0.4	6.4	0.5	0	0.9
	SQ ON	0	0	8.0	0.6	0	0.9
7	OFF	0	0	1.0	0.1	0	0.5
	SQ ON	0.6	0	0	0.1	0	0.5
8	TX Buffer	9.2	5.4	13.6	2.4	2.8	12.4
9	X'tal OSC	5.7	5.2	7.1	5.1	4.6	6.5
10	PLL VCO	4.5	3.9	8.9	4.5	3.9	8.1
11	VCO Buffer	3.4	2.9	8.9	3.3	2.6	8.1
12	TX Switching	8.7	8.9	1.3	7.5	8.2	8.0
13	MIC AMP	2.8	3.2	13.5	2.1	1.5	6.4
14	AMC AMP	0	2.7	0	0	0	0
15	AMC AMP	4.5	4.5	0	4.0	4.0	0
16	RX Switching	8.8	8.1	8.9	0	1.0	8.1
17	REG.	9.5	8.9	12.8	9.5	8.9	12.8
501	TX Final	0	0	13.4	0	0	13.4
502	TX Driver	0	0	13.4	0	0	13.4

PC 33 VOLTAGE CHART

(continued)

IC NO.		IC PIN NO.	RX (v)	TX (v)
501	AF Power AMP	1	7.1	7.1
		2	13.7	13.7
		3	13.1	13.1
		4	0	0
		5	0.1	0.1
		6	0	0
		7	0.5	0.5
		8	0.6	0.6
1	PLL IC	1	7.7	7.8
		2	3.2	3.1
		3	0	0
		4	1.6	5.7
		5	3.6	3.6
		6	3.6	3.6
		7	2.0	3.2
		8	0.9	6.6
		9	3.2	3.2
		10	0.7	0.7
		11	0.7	0.7
		12	0.7	0.7
		13	7.8	7.7
		14	7.7	7.7
		15	0	0
		16	7.7	7.7
		17	7.8	7.7
		18	0	0
2	TX Mixer	1	2.6	2.6
		2	2.0	2.0
		3	1.2	1.2
		4	1.8	2.5
		5	0	0
		6	1.2	8.1
		7	2.0	2.0
		8	4.4	4.5
		9	1.3	7.7
551	LED Drive	1	9.9	9.6
		2	9.9	9.6
		3	9.9	9.6
		4	10.3	10.0
		5	0	0
		6	1.0	0.5
		7	1.0	1.2
		8	0.1	0.2
		9	8.3	8.2

PC 55 VOLTAGE CHART

TR NO.		RX			TX		
		B	E	C	B	E	C
1	RF AMP	1.1	0.4	7.5	0.4	0	1.0
2	1st Mix	1.2	0.6	12.2	0.4	0	12.6
3	2nd Mix	0.6	0	7.5	0.3	0	1.0
4	IF AMP	0.7	0	2.2	0.2	0	1.0
5	IF AMP	2.2	1.5	12.2	1.0	0.4	12.6
6	OFF	1.0	0.4	6.4	0.5	0	0.9
	SQ ON	0	0	8.0	0.6	0	0.9
7	OFF	0	0	1.0	0.1	0	0.5
	SQ ON	0.6	0	0	0.1	0	0.5
8	TX Buffer	9.2	5.4	13.6	2.4	2.8	12.4
9	X'tal OSC	5.7	5.2	7.1	5.1	4.6	6.5
10	PLL VCO	4.5	3.9	8.9	4.5	3.9	8.1
11	VCO Buffer	3.4	2.9	8.9	3.3	2.6	8.1
12	TX Switching	8.7	8.9	1.3	7.5	8.2	8.0
13	MIC AMP	2.8	3.2	13.5	2.1	1.5	6.4
14	AMC AMP	0	2.7	0	0	0	0
15	AMC AMP	4.5	4.5	0	4.0	4.0	0
16	RX Switching	8.8	8.1	8.9	0	1.0	8.1
17	REG.	9.5	8.9	12.8	9.5	8.9	12.8
501	TX Final	0	0	13.4	0	0	13.4
502	TX Driver	0	0	13.4	0	0	13.4
18	RF ATT.	0.6	0	0.1	0.3	0	0.4

PC 55 VOLTAGE CHART
(continued)

IC NO.		IC PIN NO.	RX (v)	TX (v)
501	AF Power AMP	1	7.1	7.1
		2	13.7	13.7
		3	13.1	13.1
		4	0	0
		5	0.1	0.1
		6	0	0
		7	0.5	0.5
		8	0.6	0.6
1	PLL IC	1	7.7	7.8
		2	3.2	3.1
		3	0	0
		4	1.6	5.7
		5	3.6	3.6
		6	3.6	3.6
		7	2.0	3.2
		8	0.9	6.6
		9	3.2	3.2
		10	0.7	0.7
		11	0.7	0.7
		12	0.7	0.7
		13	7.8	7.7
		14	7.7	7.7
		15	0	0
		16	7.7	7.7
		17	7.8	7.7
		18	0	0
2	TX Mixer	1	2.6	2.6
		2	2.0	2.0
		3	1.2	1.2
		4	1.8	2.5
		5	0	0
		6	1.2	8.1
		7	2.0	2.0
		8	4.4	4.5
		9	1.3	7.7
3	LED Drive	1	9.9	9.6
		2	9.9	9.6
		3	9.9	9.6
		4	10.3	10.0
		5	0	0
		6	1.0	0.5
		7	1.0	1.2
		8	0.1	0.2
		9	8.3	8.2

SEMICONDUCTOR PINOUTS

LB1423

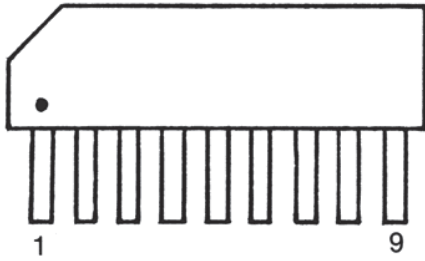

TA7310PU

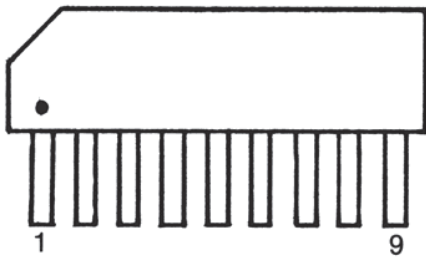

MB3712

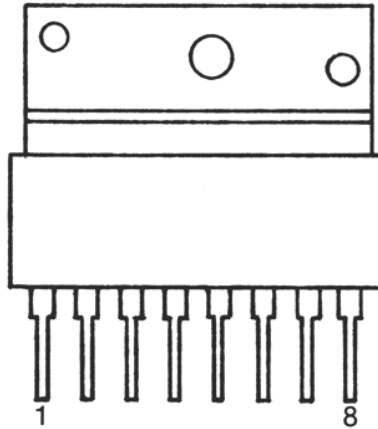

TC9106

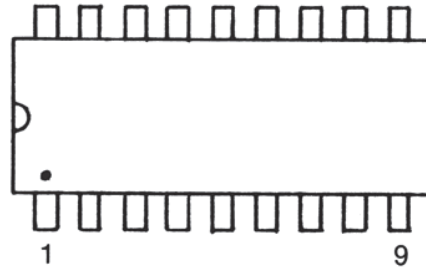

- 2SC380TM
- 2SC941TM
- 2SC1815
- 2SC1923
- 2SC1015

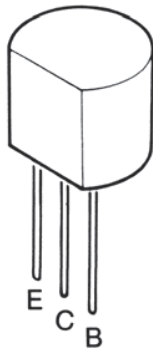

2SD471L



- X2 094
- 1N4003
- 1S2075K
- 1SV73-ED

TLR-205

GL-9PR2

2SC2028B

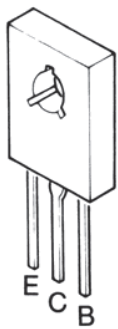

2SC2029

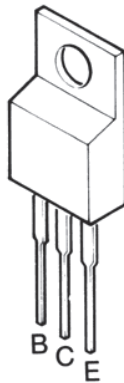

TRANSISTORS

- E = Emitter
- C = Collector
- B = Base

DIODES, LED's

- A = Anode
- C = Cathode

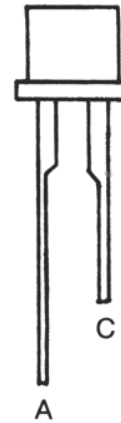
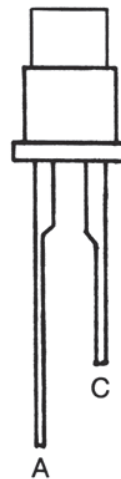

PARTS LIST PC33/PC55

PART NO.	DESCRIPTION	VENDOR	PC33 SYMBOL	PC55 SYMBOL
– Capacitors –				
	CAPACITOR: CERAMIC 47PF50VKCH	BCCC814705Z	C076	C076
	CAPACITOR: CERAMIC 10PF50VKSL	BCCG811005Z	C089	C089
	CAPACITOR: CERAMIC 100PF50VKSL	BCCG811015Z	C086	
	CAPACITOR: CERAMIC 15PF50VKSL	BCCG811505Z	C016	C016
	CAPACITOR: CERAMIC 150PF50VKSL	BCCG811515Z	C072	C072
			C096	C096
	CAPACITOR: CERAMIC 22PF50VKSL	BCCG812205Z	C068	C068
				C501
	CAPACITOR: CERAMIC 220PF50VKSL	BCCG812215Z	C004	C004
	CAPACITOR: CERAMIC 180PF50VKSL	BCCG811815Z	C032	C032
			C042	C042
	CAPACITOR: CERAMIC 220PF50VKSL	BCCG812715Z	C034	C034
	CAPACITOR: CERAMIC 33PF50VKSL	BCCG813305Z	C033	C033
			C037	C041
			C041	C070
			C070	C037
	CAPACITOR: CERAMIC 39PF50VKSL	BCCG813905Z	C036	C036
	CAPACITOR: CERAMIC 390PF50VKSL	BCCG813915Z	C073	C073
	CAPACITOR: CERAMIC 470PF50VKSL	BCCG814715Z	C077	C077
	CAPACITOR: CERAMIC 5PF50VCSL	BCCG815091Z	C083	C083
			C088	C088
	CAPACITOR: CERAMIC 56PF50VKSL	BCCG815605Z	C044	C044
	CAPACITOR: CERAMIC 68PF50VKSL	BCCG816805Z	C501	
	CAPACITOR: CERAMIC 82PF50VKSL	BCCG818205Z	C085	C085
	CAPACITOR: CERAMIC 15PF50VKRH	BCCR811505Z	C005	C005
	CAPACITOR: CERAMIC 33PF50VKRH	BCCR813305Z	C080	C080
	CAPACITOR: CERAMIC 100PF50VKUJ	BCCU811015Z	C084	C084
	CAPACITOR: CERAMIC 220PF50VKUJ	BCCU812215Z	C081	C081
	CAPACITOR: CERAMIC 68PF50VKUJ	BCCU816805Z	C079	C079
	CAPACITOR: ELECTROLYTIC 330UF25V	BCEF513316Z	C087	C087
	CAPACITOR: ELECTROLYTIC 470UF10V	BCEK114716Z	C060	C060
	CAPACITOR: ELECTROLYTIC 10UF25V	BCEK511006Z	C006	C006
	CAPACITOR: ELECTROLYTIC 2.2UF25V	BCEK512296Z	C056	C056
1800-0310	CAPACITOR: ELECTROLYTIC 100UF10V	BCEL111010Z	C113	C113
1800-0331	CAPACITOR: ELECTROLYTIC 22UF10V	BCEL112200Z	C098	C098
1800-0323	CAPACITOR: ELECTROLYTIC 33UF10V	BCEL113300Z	C051	C051
1800-0324	CAPACITOR: ELECTROLYTIC 47UF10V	BCEL114700Z	C097	C097
			C107	C107
1800-0327	CAPACITOR: ELECTROLYTIC 470UF10V	BCEL114710Z	C074	C074
1800-0306	CAPACITOR: ELECTROLYTIC 10UF16V	BCEL311000Z	C027	C008
				C027
			C053	C053
			C111	C111
				C116
	CAPACITOR: ELECTROLYTIC 33UF16V	BCEL313300Z	C057	C057
1800-0316	CAPACITOR: ELECTROLYTIC 47UF16V	BCEL314700Z	C094	C094
	CAPACITOR: ELECTROLYTIC 470UF16V	BCEL314710Z	C114	C114
	CAPACITOR: ELECTROLYTIC 2.2UF25V	BCEL512290Z	C030	C030
			C064	C064
			C065	C065

PART NO.	DESCRIPTION	VENDOR	PC33 SYMBOL	PC55 SYMBOL
– Capacitors – (continued)				
1800-0304	CAPACITOR: ELECTROLYTIC 4.7UF25V	BCEL514790Z	C019	C019
1800-0302	CAPACITOR: ELECTROLYTIC 1UF50V	BCEL811090Z	C024	C024
			C106	C106
1800-0340	CAPACITOR: ELECTROLYTIC 0.22UF50V	BCEL812280Z	C067	C067
	CAPACITOR: ELECTROLYTIC 1000UF25VM	BCER511026Z	C115	C115
	CAPACITOR: SEMI-CONDUCTOR (SR) 0.01UF25VM	BCGC511036Z	C102	C102
			C151	C151
	CAPACITOR: SEMI-CONDUCTOR (SR) 0.1UF25VM	BCGC511046Z	C059	C059
			C071	C071
	CAPACITOR: SEMI-CONDUCTOR (SR) 0.015UF25VM	BCGC511536Z	C028	C028
			C095	C095
	CAPACITOR: SEMI-CONDUCTOR (SR) 0.022UF25VM	BCGC512236Z	C153	C153
	CAPACITOR: SEMI-CONDUCTOR (SR) 0.033UF25VM	BCGC513336Z	C100	C100
	CAPACITOR: SEMI-CONDUCTOR (SR) 0.0047UF25VM	BCGC514726Z	C026	C026
			C120	C120
	CAPACITOR: SEMI-CONDUCTOR (SR) 0.047UF25VM	BCGC514736Z	C018	C018
			C152	C152
1800-0106	CAPACITOR: CERAMIC 0.047UF25VZZF	BCKC514730Z	C159	C159
			C105	C105
			C123	C123
1800-0119	CAPACITOR: CERAMIC 0.01UF50VMYD	BCKD811036Z	C045	C045
			C046	C046
			C047	C047
			C049	C049
			C154	C154
1800-0118	CAPACITOR: CERAMIC 0.0022UF50VMYD	BCKD812226Z	C048	C048
	CAPACITOR: CERAMIC 0.0047UF50VMYD	BCKD814726Z	C021	C021
			C043	C043
			C112	C112
			C155	C155
	CAPACITOR: CERAMIC 0.001UF50VZYF	BCKG811020Z	C001	C001
			C011	C011
			C050	C050
			C091	C091
			C103	C103
			C108	C108
			C109	C109
			C110	C110
			C118	C118
			C119	C119
			C121	C121
			C551	C551
			C553	C553
			C555	C555
1800-0148	CAPACITOR: CERAMIC 0.01UF50VZYF	BCKG811030Z	C003	C003
			C007	C007
			C009	C009
1800-0148	CAPACITOR: CERAMIC 0.01UF50VZYF	BCKG811030Z	C010	C010
			C013	C013
			C035	C035
			C052	C052
			C061	C061

PART NO.	DESCRIPTION	VENDOR	PC33 SYMBOL	PC55 SYMBOL
— Capacitors — (continued)				
			C062	C062
			C066	C066
			C069	C069
			C078	C078
			C082	C082
			C090	C090
			C092	C092
			C104	C104
			C156	C156
			C157	C157
			C158	C158
			C550	C550
			C552	C552
	CAPACITOR: CERAMIC 0.022UF50VZYF	BCKG812230Z	C012	C012
	CAPACITOR: CERAMIC 0.0047UF50UF50VZYF	BCKG814720Z	C029	C029
			C099	C099
			C117	C117
			C120	C120
— Diodes —				
2000-0651	DIODE: ZENER XZ-094	BDAY0020011	D014	D014
2000-0332	DIODE: 1S2075K	BDAY0063001	D001	D001
			D002	D002
			D003	D004
			D004	D005
			D005	D006
			D006	D007
			D007	D008
			D008	D011
				D551
				D552
				D553
				D554
				D555
				D556
				D557
			D011	D011
			D012	D012
			D013	D013
				D016
				D017
				D018
			D019	D019
2000-0608	DIODE: 1N4003	BDAY0133001	D009	D009
			D015	D015
2000-0604	DIODE: LDR204AL	BDAY0202001	D550	D550
2000-0652	DIODE: 1SV73-EB	BDAY0220001	D010	D010
2000-0653	DIODE: LED TLR205	BDAY0231001	D558	D558
			D559	D559
			D560	D560
			D561	D561
2000-0654	DIODE: LED GL-9PR2	BDAY0242001	D562	D562

PART NO.	DESCRIPTION	VENDOR	PC33 SYMBOL	PC55 SYMBOL
– Transistors –				
2000-0426	TRANSISTOR: 2SA1015-GR	BDBA1015303	TR012 TR015	TR012 TR015
2000-2288	TRANSISTOR: 2SC380TM-O	BDBC0380523	TR002 TR004 TR005 TR009 TR010	TR002 TR004 TR005 TR009 TR010
2000-0457	TRANSISTOR: 2SC380TM-Y	BDBC0380523	TR011	TR011
2000-0246	TRANSISTOR: 2SC941TM-O	BDBC0380525	TR003	TR003
2000-0244	TRANSISTOR: 2SC1815-O	BDBC0941523	TR008	TR008
2000-0245	TRANSISTOR: 2SC1815-Y	BDBC1815114	TR016	TR016 TR018
2000-0428	TRANSISTOR: 2SC1923-O	BDBC1815124	TR006 TR007 TR013 TR014	TR006 TR007 TR013 TR014
2000-0270	TRANSISTOR: 2SC2028-B/20	BDBC1923114	TR001	TR001
2000-0271	TRANSISTOR: 2SC2029-B/10	BDBC2028711	TR502	TR502
2000-0276	TRANSISTOR: 2SD471-L	BDBC2029710	TR501	TR501
2000-0017	INTEGRATED CIRCUIT: TA7310P-U	BDBD0471111	TR017	TR017
2000-0035	INTEGRATED CIRCUIT: TC9106BP	BDEY0109002	IC002	IC002
2000-0037	INTEGRATED CIRCUIT: MB3712	BDEY0113002	IC001	IC001
2000-1038	INTEGRATED CIRCUIT: LB1423	BDEY0157001	IC501	IC501
		BDEY0430001	IC551	IC003
– Crystals –				
2200-0309	FILTER: CERAMIC FL-009 CFU-455H2	BFLY0009001	FT002	
2200-0301	FILTER: CERAMIC FL048	BFLY0048001	FT001	FT001
2200-0302	FILTER: CERAMIC FL066 CFW-455HT	BFLY0066001		FT002
2100-0001	CRYSTAL: OX-074 10.240	BOXY0074001	X001	X001
1100-0021	JACK: JK-089	BJKY0089001	J003	J003 J004
1100-0098	JACK: ANT JK-230	BJKY0230001	J501	J501
	JACK: JK-250	BJKY0250001	J552	J552
– Coils –				
	COIL: LB-119	BLBY0119001		L003
2200-1115	COIL: LB-313	BLBY0313001	L005	L005
2200-1116	COIL: LB-345	BLBY0345001	L001	L001
2200-1117	COIL: LB-346	BLBY0346001	L002	L002
2200-1118	COIL: LB-347	BLBY0347001	L012	L012
2200-1119	COIL: LB-348	BLBY0348001	L014	L014
2200-1120	COIL: LB-349	BLBY0239001	L015	L015
2200-1121	COIL: LB-352	BLBY0352001	L004	L004
2200-1122	COIL: LB-360	BLBY0360001	L011	L011
2200-1123	COIL: LB-361	BLBY0361001	L013	L013
2200-1201	COIL: LC-073	BLCY0073001	L008	L008
2200-1202	COIL: LC-130/RFCOIL	BLCY0130001	L010	L010
2200-1302	COIL: LD-033	BLDY0033001	L009	L009
2200-0103	COIL: LD-077	BLDY0077001	L016	L016
2200-1504	COIL: LE-093	BLEY0093001	L006 L007	L006 L007
2300-0008	TRANSFORMER: AF CHOKE TF-157	BTFY0157001	T002	T002

PART NO.	DESCRIPTION	VENDOR	PC33 SYMBOL	PC55 SYMBOL
— Coils — (continued)				
2600-0045	TRANSFORMER: TF-285	BTFY0285001	T001	T001
3200-0043	MICROPHONE: MK-291	BMKY0291001	MC501	MC501
3500-0165	PC BOARD: FRONT PA-175AA	BPAY0175AAZ	B551	
3500-0166	PC BOARD: FRONT PA-173AA	BPAY0173AAZ		B551
— Resistors —				
	RESISTOR: CARBON AXIAL LEAD: 100 1/8WJ	BRPB181014Z	R049	R049
	RESISTOR: CARBON AXIAL LEAD: 1K 1/8J	BRPB181024Z	R106 R553	
				R010 R012 R017 R018 R040 R057 R064 R072 R101 R102 R103 R105 R094
	RESISTOR: CARBON AXIAL LEAD: 10K 1/8WJ	BRPB181034Z	R062	R062
	RESISTOR: CARBON AXIAL LEAD: 12 1/8WJ	BRPB181204Z	R043	R043
	RESISTOR: CARBON AXIAL LEAD: 2.2 1/8WJ	BRPB182224Z	R038	R038
	RESISTOR: CARBON AXIAL LEAD: 330 1/8WJ	BRPB183314Z	R009	R009
	RESISTOR: CARBON AXIAL LEAD: 3.3 1/8 WJ	BRPB183324Z	R047	R047
	RESISTOR: CARBON AXIAL LEAD: 33K 1/8WJ	BRPB183334Z	R037 R058	
	RESISTOR: CARBON AXIAL LEAD: 56K 1/8WJ	BRPB185634Z		R037
	RESISTOR: CARBON AXIAL LEAD: 47K 1/8WJ	BRPB184734Z	R051	R051
1900-0211	RESISTOR: SEMI-FIXED RT-182 100KB	BRTY0182104	VR001 VR003	VR001
1900-0202	RESISTOR: SEMI-FIXED RT-182 50KB	BRTY0182503	VR002	VR002 VR003
	RESISTOR: CARBON FORMED VERT 100 1/8J	BRUB181014Z	R091	R556 R091
			R556	P562
	RESISTOR: CARBON FORMED VERT: 1K 1/8W	BRUB181024Z	R012 R017 R018 R057 R064 R072 R094 R101 R102 R103 R105 R552 R555 R558 R559	R553 R554 R559 R560
				R552 R555 R558

PART NO.	DESCRIPTION	VENDOR	PC33 SYMBOL	PC55 SYMBOL
– Resistors – (continued)				
			R560	
			R561	R561
			R036	R036
RESISTOR: CARBON FORMED VERT 10K 1/8WJ	BRUB181034Z			R002
			R060	R060
			R562	R095
RESISTOR: CARBON FORMED VERT 100K 1/8WJ	BRUB181044Z		R033	
			R086	R086
RESISTOR: CARBON FORMED VERT 1M 1/8WJ	BRUB181054Z		R029	R029
RESISTOR: CARBON FORMED VERT 1 1/8WJ	BRUB181094Z		R042	R042
RESISTOR: CARBON FORMED VERT 12 1/8WJ	BRUB181204Z		R016	
RESISTOR: CARBON FORMED VERT 1.5K 1/8WJ	BRUB181524Z		R050	R050
RESISTOR: CARBON FORMED VERT 18K 1/8WJ	BRUB181834Z		R024	R024
			R030	R003
RESISTOR: CARBON FORMED VERT 180K 1/8WJ,	BRUB181844Z		R015	R080
			R080	
RESISTOR: CARBON FORMED VERT 220 1/8WJ	BRUB182214Z		R007	R007
			R021	R021
			R022	R022
			R074	R074
RESISTOR: CARBON FORMED VERT 2.2K 1/8WJ	BRUB182224Z		R020	R020
			R073	R073
			R082	R082
			R087	R087
RESISTOR: CARBON FORMED VERT 22K 1/8WJ	BRUB182234Z		R054	R030
				R054
			R067	R067
			R088	R088
RESISTOR: CARBON FORMED VERT 220K 1/8WJ	BRUB182244Z		R071	R071
				R015
RESISTOR: CARBON FORMED VERT 27 1/8WJ	BRUB182704Z		R048	R048
RESISTOR: CARBON FORMED VERT 2.7K 1/8WJ	BRUB182724Z		R065	R065
			R078	R078
RESISTOR: CARBON FORMED VERT 33 1/8WJ	BRUB183304Z		R041	R041
			R058	R058
RESISTOR: CARBON FORMED VERT 12K 1/8WJ	BRUB181234Z			R006
RESISTOR: CARBON FORMED VERT 22K 1/8WJ	BRUB182204Z			R016
RESISTOR: CARBON FORMED VERT 330 1/8WJ	BRUB183314Z		R014	R014
			R035	R035
RESISTOR: CARBON FORMED VERT 3.3K 1/8WJ	BRUB183324Z		R004	R004
			R010	R010
			R039	R039
			R045	R045
			R070	R070
			R081	R081
			R084	R084
			R085	R085
			R096	R096
RESISTOR: CARBON FORMED VERT 33K 1/8WJ	BRUB183334Z		R025	R001
				R025
			R052	R052
RESISTOR: CARBON FORMED VERT 39K 1/8WJ	BRUB183934Z		R068	R068
RESISTOR: CARBON FORMED VERT 47 1/8WJ	BRUB184704Z		R023	R023

PART NO.	DESCRIPTION	VENDOR	PC33 SYMBOL	PC55 SYMBOL
– Resistors – (continued)				
	RESISTOR: CARBON FORMED VERT 470 1/8WJ	BRUB184714Z	R044 R013 R040	R044 R013
	RESISTOR: CARBON FORMED VERT 4.7K 1/8WJ	BRUB184724Z	R104 R026 R061 R063 R089	R104 R026 R061 R063 R089
	RESISTOR: CARBON FORMED VERT 47K 1/8WJ	BRUB184734Z	R019 R076 R083	R019 R076 R083
	RESISTOR: CARBON FORMED VERT 0.5 1/8WJ	BRUB185084Z	R056	R056
	RESISTOR: CARBON FORMED VERT 560 1/8WJ	BRUB185614Z	R005	R005 R039
	RESISTOR: CARBON FORMED VERT 5.6 1/8WJ	BRUB185624Z	R092 R008 R079	R092 R008 R079
	RESISTOR: CARBON FORMED VERT 56K 1/8WJ	BRUB185634Z	R028	R037 R028
			R031 R032 R053 R069	R031 R032 R053 R069
	RESISTOR: CARBON FORMED VERT 68 1/8WJ	BRUB186804Z	R075	R075
	RESISTOR: CARBON FORMED VERT 680 1/8WJ	BRUB186814Z	R059	
	RESISTOR: CARBON FORMED VERT 6.8K 1/8WJ	BRUB186824Z	R046	R046
	RESISTOR: CARBON FORMED VERT 68K 1/8WJ	BRUB186834Z	R027	R027 R033
	RESISTOR: CARBON FORMED VERT 8.2K 1/8WJ	BRUB188224Z	R055	R055
	RESISTOR: CARBON FORMED VERT 82K 1/8WJ	BRUB188234Z	R066	R066
	RESISTOR: CARBON FORMED VERT 820K 1/8WJ	BRUB188244Z	R034	R034
	RESISTOR: CARBON FORMED VERT 8.2 1/8WJ	BRUB188294Z	R011 R093	R011 R093
1900-1104	RESISTOR: VARIABLE RV-567 50KB	BRVY0567001	VR552	VR552
1900-1105	RESISTOR: VARIABLE RV-569 50KA(S)	BRVY0569001	VR501	VR501
1900-1106	RESISTOR: VARIABLE RV-568 1KB	BRVY0568001		VR553
– Switches –				
3000-1013	SWITCH: SLIDE SW431	BSWY0431001		S554
3100-0009	SPEAKER: SP-057	BSPY0057001	SP501	SP501
3000-0160	SWITCH: ROTARY SR-220	BSRY0220001	S001	S001
3000-1012	SWITCH: SLIDE SW-430	BSWY0430001	S551	S551 S553
– Mechanical Parts –				
2700-0011	CORD: DC WZ-246	BWZY0246001	WA501	WA501
3400-0235	BUSHING: TRANSISTOR YD-019 B312D-11-A	BYDY0019003	YI501	YI501
3400-0236	BUSHING: TRANSISTOR YD-019 B309D	BYDY0019004	YI502	YI502
	INSULATION SHEET: YD-042	BYDY0042001	YI503	YI503
	INSULATION SHEET: YD-043	BYDY0043001	YI504	YI504
3400-0405	INSULATION SHEET: YD-046	BYDY0046001	YI505	YI505
3300-0580	PANEL: FRONT ABS INST CLR GRAY	GCMF214437Z		
1100-0202	SCREW: MOUNTING ABS INST CLR BLACK	GMSC405736Z		

PART NO.	DESCRIPTION	VENDOR	PC33 SYMBOL	PC55 SYMBOL
– Mechanical Parts – (continued)				
1300-1016	KNOB: CHANNEL	GNBC414438Z		
1300-1017	KNOB:	GNBY414439Z		
3300-0233	MOUNTING BRACKET:	HBCT314444Z		
3300-1026	COVER: BOTTOM	HCMB314443Z		
3300-1027	COVER: TOP	HCMT314442Z		
3300-0401	HANGER: MICROPHONE	HMHG402919Z		
	OPTICAL FILTER: DISPLAY ACRYL 1T PURPLE	KDPC414447Z		
3400-0194	NAMEPLATE: CONTROL (PC33)	KDPP414455Z		
	HOLDER: LED RUBBER BLACK	LHDL4122579Z		
	HOLDER: LED EPT BLACK	LHDL4130112		
	HOLDER: LED EPT BLACK	LHDL414448Z		
	WASHER: RUBBER	LWSR409915Z		
	SCREW: FLAT HD + M3X4 NI	SSCW133004N		
1100-0728	SCREW: BIND HD + M3X3 NI	SSCW193005N		
1100-0723	SCREW: BIND HD + M3X8 NI	SSCW193008N		
1100-0708	SCREW: TAPPING ROUND HD + D3.5X8 NI	SSCW293508N		
1100-0709	SCREW: TAPPING ROUND HD + D5X10 NI	SSCW295010N		
1100-0725	SCREW: TAPTIGHT BIND HD + M3X6 NI	SSCW343006N		
1100-0735	HEX NUT M3, ONI	SSCW430030N		
1100-0710	NUT: FLANGE	SSCW480030Z		
1100-0711	WASHER: LOCK D3.5NI	SSCW530035N		
1100-0712	WASHER: STAR D5NI	SSCW540050N		
	SPRING PLATE: KNOB D6	TSTD0200003		
	RIVET: AL, ID PLATE D3.2X3.2	TSTD0213232		
3400-0195	NAMEPLATE: CONTROL (PC55)	KPDC414446Z		