

AX 711 Service Manual

uniden **CORPORATION OF AMERICA**
6330 Castleplace Drive • Indianapolis, Indiana - 46250 • (317) 842-0280

AX 711SM © 1981

Contents

	Page
Specifications	1
Alignment Receiver	2
Alignment PLL	3
Alignment Transmitter	4
Semiconductor Voltage Chart	5
Test Equipment Set Up	6
Semiconductor Pin Configuration	7
PLL Program Chart	8
Component Layout For Alignment	9
Block Diagram	10
Schematic	11
P.C. Board Layout	12
Parts List	14

Specifications

Receiver:

Sens. For $\frac{S+N}{N} = 10\text{dB}$.5uv
Sens. For 500mw	.3uv
Squelch Threshold	.5uv
Squelch Deep	60-70dB
S-9	50uv
Frequency Range	26.965mhz to 27.450mhz
Type Of Emission	AM
AF Power At 10% Distortion	3 Watts
IF Band Width	6 khz
AF Output Impedance	8 ohm
Adjacent Channel Rejection	55 db Or Better

Transmitter

Power Output	4 Watts
Spurious Suppression	Better Than - 60dB
Percentage Of Modulation	85 - 100 %
Frequency Tolerance	\pm 1350hz
Frequency Range	26.965mhz To 27.405mhz
Type Of Emission	AM
Output Impedance	50 ohm
Frequency Method	PLL
D.C. Power Required	13.8vdc @ .5 amps RX- 1.5 amps TX

Note:

All Transmitter Adjustments Must Be Performed By A FCC 1st Or 2nd Class Radiotelephone License Holder.

Alignment Of Receiver Portion

1. Equipment Required

- A. Signal Generator (27 MHz Band, 1000Hz, 30% AM Modulation & Output Impedance 50 ohm)
- B. Audio VTVM
- C. Oscilloscope
- D. Dummy Load (8 ohm, 5 watts, resistive)
- E. DC Power Supply (13.8 V, 2 Amp.)

2. Procedure

Step	SG Connection Frequency	Preset To	Audio VTVM	Adjustment	Remarks
1.	To Ant. Connector, J401. Ch. 19 Freq. 27.185 MHz	Vol. Max. SQL. Min. ANL. Off NB. Off	To Ext. Spk. Jack 403	L1, 2,3, 4,5,6,7	Adjust for a max. Audio Output
2.	Same As Step 1	Same As Step 1	Same As Step 1	VR 2	Adjust for 2 V output with SG output level of 0.4uV
3.	Same As Step 1	Vol. Max. SQL. Max. NB/ANL: Off	Same As Step 1	VR 4 (Squelch)	Adjust for 2V output with SG output level of 1000uV
4.	Same As Step 1	Same As Step 1	Same As Step 1	VR 1	Adjust for a reading of S-9 on the S-Meter of the Transceiver with SG output level of 100 uV

Alignment Of PLL Portion

1. Test Equipment Required

- A. Oscilloscope (0-50 mhz)
- B. DC Volt Meter (10 Volts maximum, 100K ohm/Volt)

2. Alignment Procedure

Step	Preset To	Connections	Adjustments	Remarks
1	TX Mode No Modulation Channel 40	DC Volt Meter to Pin No.7 of I.C. 3 (TP2)	L 15	Adjust L15 to obtain approx. 3.0 V reading
2	TX Mode No Modulation Channel 1	Oscilloscope to secondary of L16 (TP3)	L 16	Adjust L16 for the maximum indication on oscilloscope

Alignment Of Transmitter Portion
(For Transmitter Section)

1. Equipment Required

- A. VTVM (Full Scall 1V DC With RF Probe)
- B. RF Output Power Meter
- C. Tunable Field Intensity Meter (Wave Meter)
- D. Frequency Counter (0 - 30 MHz)
- E. DC Power Supply (13.8V/2 Amp.)
- F. 50 ohm Load And Attenuator
- G. Oscilloscope (0 - 30 MHz)
- H. AF Oscillator

2. Procedure

Step	Preset To	Conditions	Alignment	Remarks
1.	TX Mode No Modulation Channel 19	RF Output Power Meter to Ant. Jack , J401 VTVM to TP4	L 17, 18	Adjust for a maximum indication on VTVM
2.	Same As Step 1	RF Output Power Meter to Ant. Jack , J401	L 10, L 14	Adjust for a maximum indication on RF Output Meter
3.	Same As Step 1	Same As Step 2	L 10	Adjust to obtain nominal 3.8 W of RF Output Power
4.	Repeat the above adjustments, in order to confirm if the adjustments were made correctly.			
5.	TX Mode Ch. 19, 1 KHz ,100mV Applied to mic input for MOD	Audio Generator to microphone Jack J501 Oscilloscope to Ant. Jack ,J401 through a suitable load and attenuator	VR 5	Adjust for 95% Modulation
6.	Same As Step 1	RF Output Power Meter To Ant. Jack J401	VR 3	Check that RF Output Power Meter reads 3.8 then adjust VR 3 so that the meter pointer of the trans- ceiver just approaches 3 to 4 mark

SEMI-CONDUCTOR VOLTAGE CHART, AX 711
 () Indicates Squelch

ALL VOLTS RESEARCHED WITH A 200, 00 OHM
 Per Volt VTVM Or VOM CH 19 * Indicates Bright

TR	RX			TX			TR	RX			TX			TR	RX			TX			
	B	C	E	B	C	E		B	C	E	B	C	E		B	C	E	B	C	E	
1	1.9	9.3	1.2				15	5.2	6.8	5.0											
2	1.2	8.7	.6				16	9.2	0	8.6	7.8	8.5	8.6	1	0	9.4	.6				
3	.6	1.7	0				17	9.2	12.8	8.6	9.2	12.0	8.6	2	0	12.8	1.6				
4	1.7	13.0	1.1				18	3.3	12.6	2.8											
5	.6	.1	0				18*	7.2	9.7	6.6											
6	0	1.2	0				19	.7	0	0	.2	1.8	0								
6	(.6)	(0)	(0)				20	3.4	13.0	2.6											
7							21	3.4	7.0	0											
8							22	13.5	0	13.5											
9							23	0	0	0											
10	1.2	5.5	.6																		
11	3.2	5.8	2.7																		
12	2.0	2.8	1.4																		
13																					
14																					
IC	Pin	1	2	3	4	5	6	7	8	9	10	11	12	13	14	15	16	17	18	19	20
1	13.5	6.3	0	-1	1.0	1.0	1.0	0	0	6.8	12.8										
2	2.6	2.2	1.4	2.4	0	8.7	8.7	1.8	4.6	8.4											
3	7.1	2.8	0	6.8	3.2	3.2	3.2	1.7	0	2.9	.6	.6	.6	7.0	7.0	7.0	7.0	0	0	0	0

PLL Test Setup

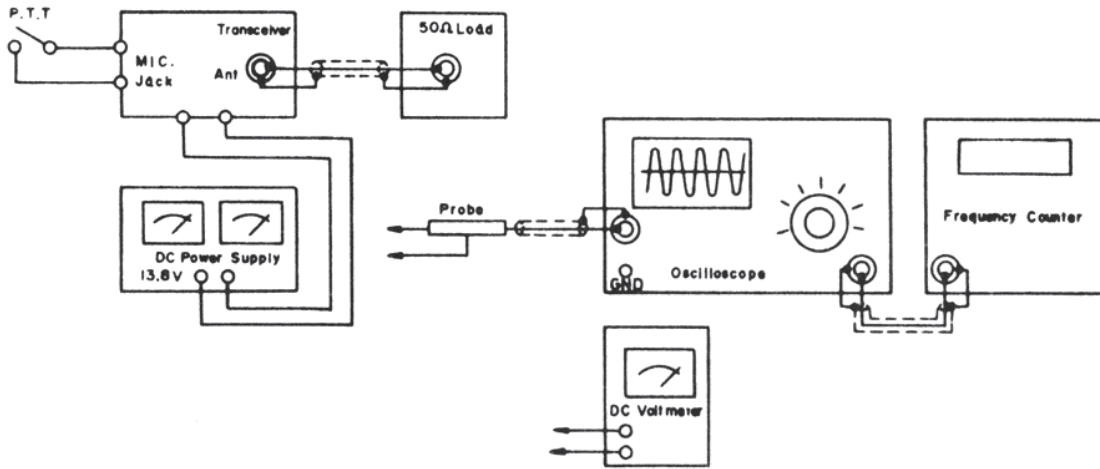

Receiver Test Setup

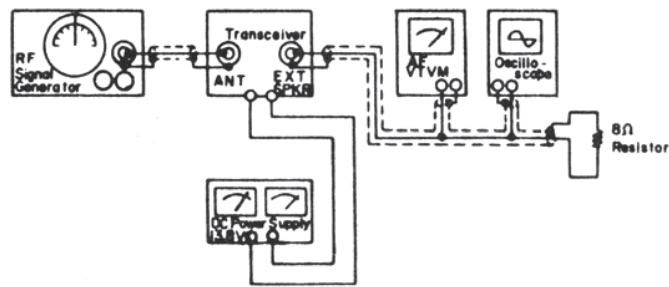

Transmitter Test Setup

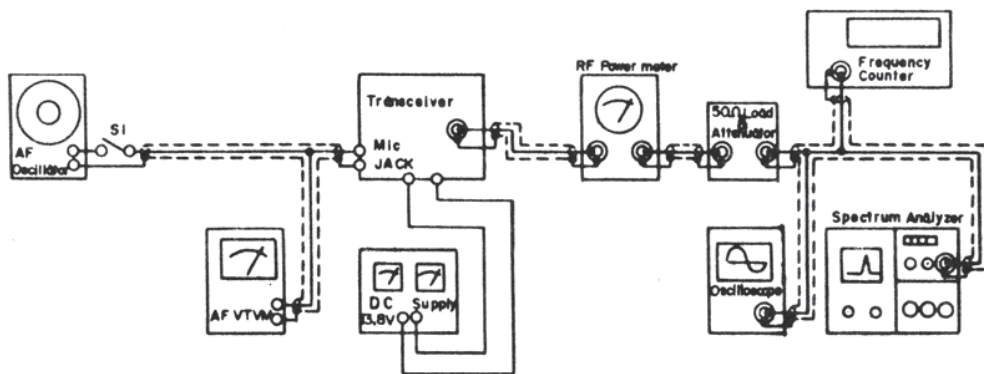

TA7222

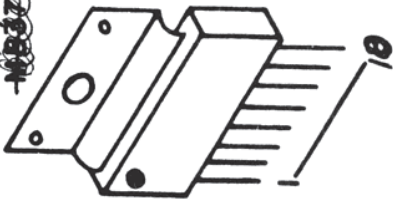

TA7310P



9106P

TC9109P

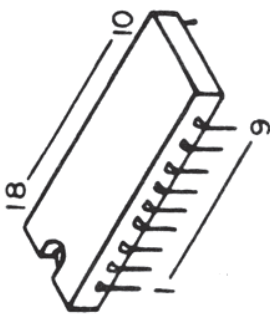

- 2SA733-P
- 2SC945A-Q
- 2SC1675-M
- 2SC2076-C



2SC1342-B



2SC2028-B/20



2SC2029-B/10



IN60-AM



IS2075-K

IS2076

SRIK-1

IS34

CZ-094

WZ-071

O5Z7.5-UNI

IS2688-EA

TLR-321

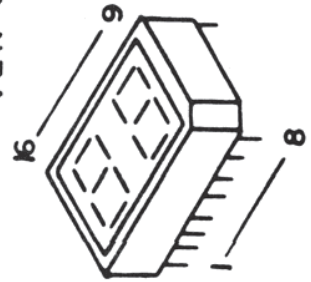

PER-24



Channel No.	Program Input Data							
	1F	1A	1G	1E	1D	2C	2A	2F
1	H	H	H	H	H	H	H	H
2	H	L	L	L	L	H	H	H
3	H	L	L	H	L	H	H	H
4	L	H	L	H	H	H	H	H
5	L	L	L	H	L	H	H	H
6	L	H	L	L	L	H	H	H
7	H	L	H	H	H	H	H	H
8	L	L	L	L	L	H	H	H
9	L	L	L	H	H	H	H	H
10	L	L	H	L	L	L	H	H
11	H	H	H	H	H	L	H	H
12	H	L	L	L	L	L	H	H
13	H	L	L	H	L	L	H	H
14	L	H	L	H	H	L	H	H
15	L	L	L	H	L	L	H	H
16	L	H	L	L	L	L	H	H
17	H	L	H	H	H	L	H	H
18	L	L	L	L	L	L	H	H
19	L	L	L	H	H	L	H	H
20	L	L	H	L	L	H	L	H
21	H	H	H	H	H	H	L	H
22	H	L	L	L	L	H	L	H
23	H	L	L	H	L	H	L	H
24	L	H	L	H	H	H	L	H
25	L	L	L	H	L	H	L	H
26	L	H	L	L	L	H	L	H
27	H	L	H	H	H	H	L	H
28	L	L	L	L	L	H	L	H
29	L	L	L	H	H	H	L	H
30	L	L	H	L	L	L	L	H
31	H	H	H	H	H	L	L	H
32	H	L	L	L	L	L	L	H
33	H	L	L	H	L	L	L	H
34	L	H	L	H	H	L	L	H
35	L	L	L	H	L	L	L	H
36	L	H	L	L	L	L	L	H
37	H	L	H	H	H	L	L	H
38	L	L	L	L	L	L	L	H
39	L	L	L	H	H	L	L	H
40	L	L	H	L	L	L	H	L

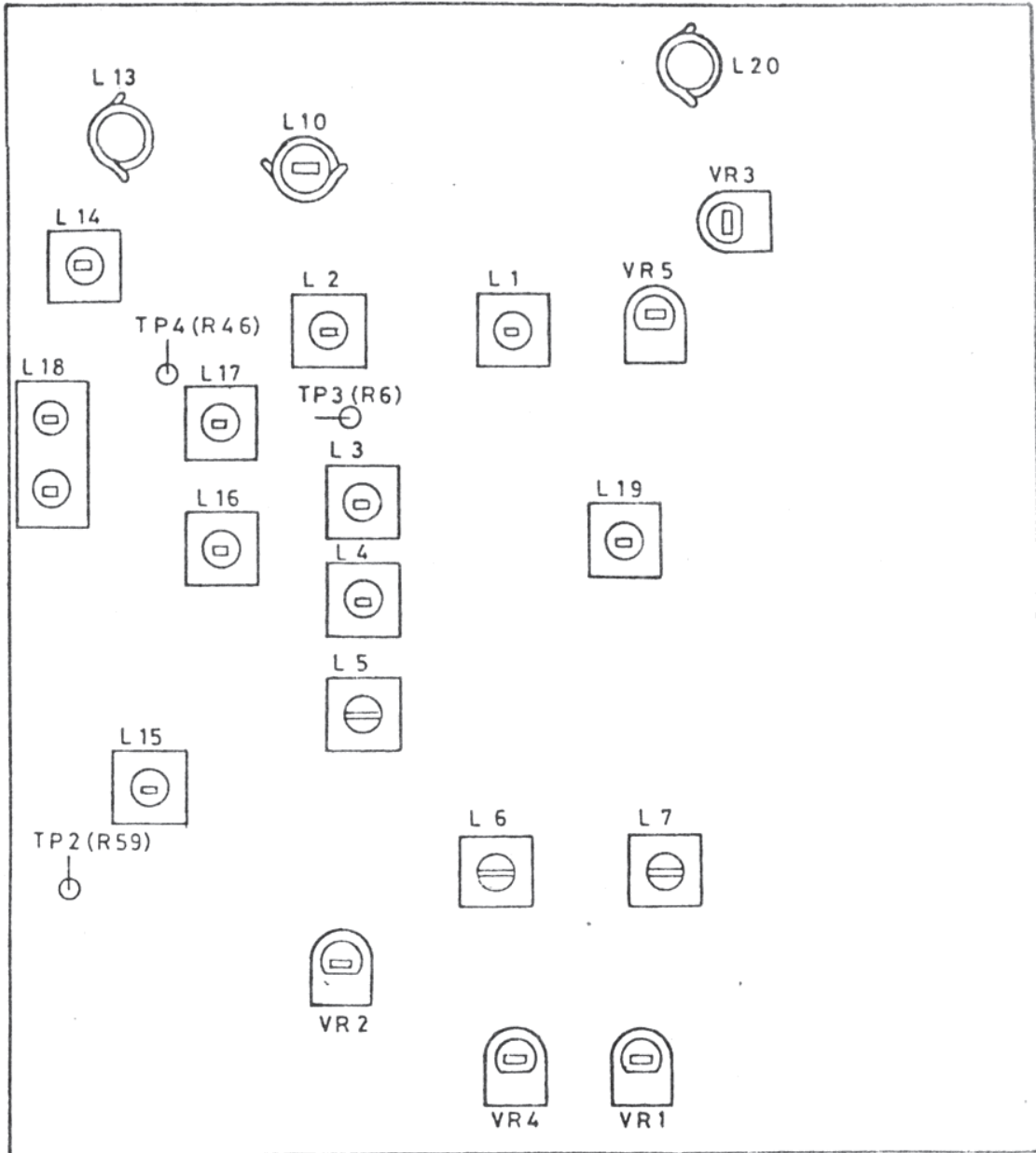

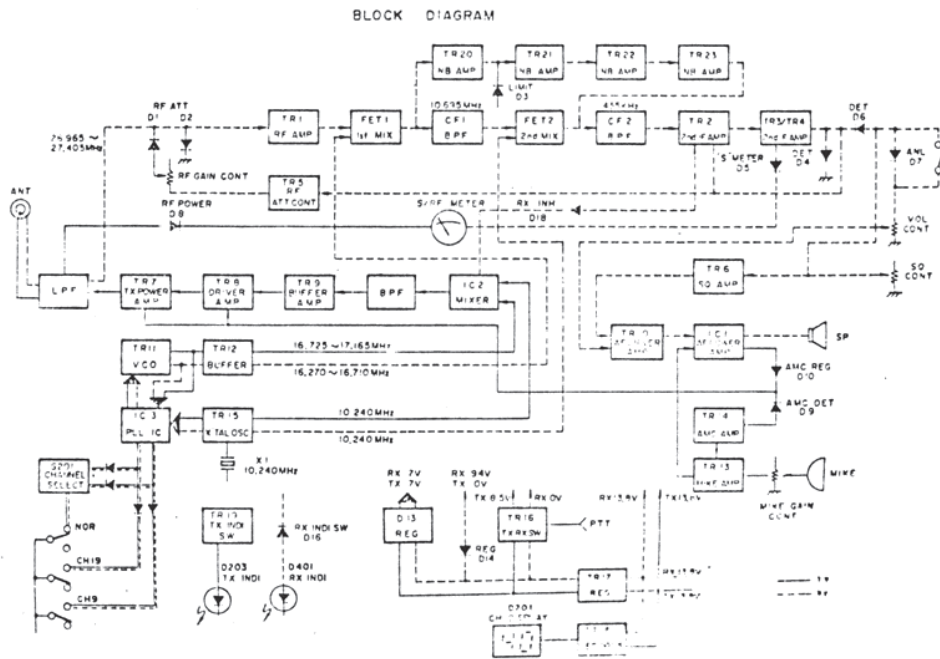
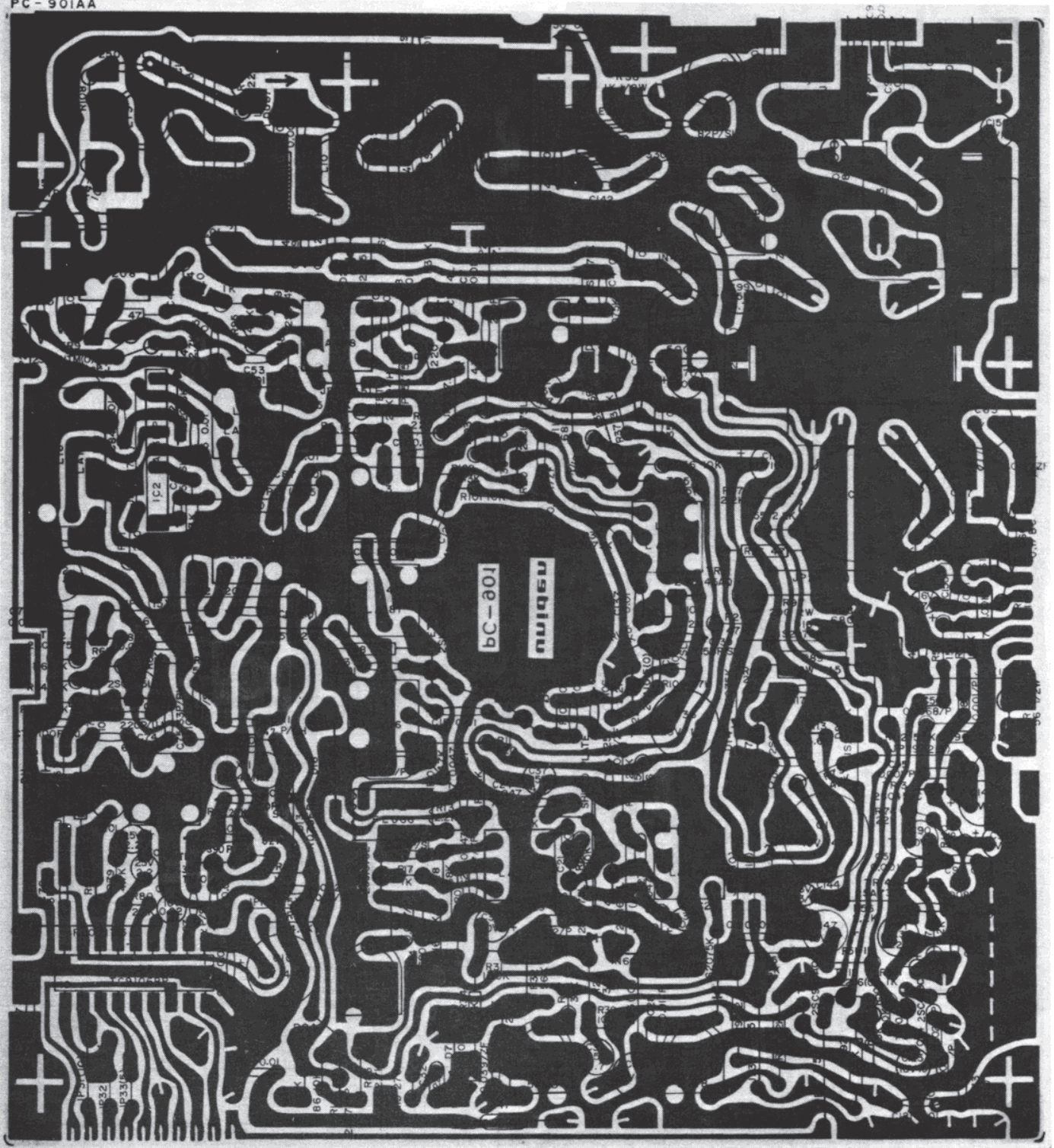
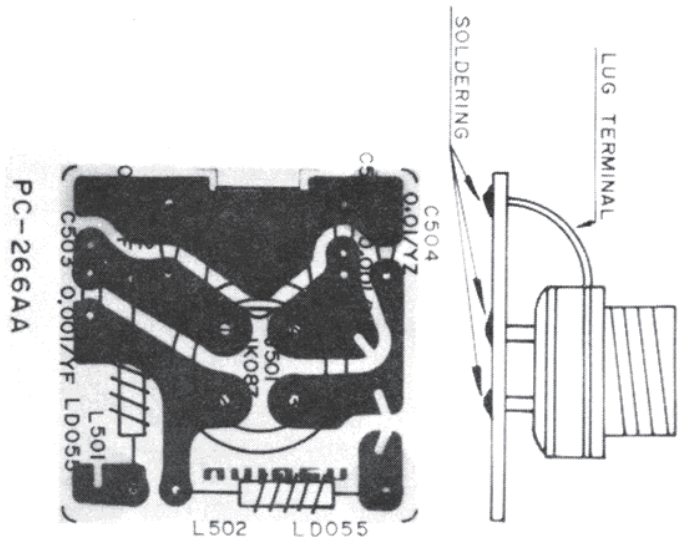

Table A Frequency Chart Of VCO And Divide Ratio N

Antenna Frequency (MHz)	Channel Number	For Transmit(R/T=H)		For Receive(R/T=L)	
		Divide Ratio (N)	VCO Frequency (KHz)	Divide Ratio (N)	VCO Frequency (KHz)
26.965	1	3,345	16,725	3,254	16,270
26.975	2	3,347	16,735	3,256	16,280
26.985	3	3,349	16,745	3,258	16,290
27.005	4	3,353	16,765	3,262	16,310
27.015	5	3,355	16,775	3,264	16,320
27.025	6	3,357	16,785	3,266	16,330
27.035	7	3,359	16,795	3,268	16,340
27.055	8	3,363	16,815	3,272	16,360
27.065	9	3,365	16,825	3,274	16,370
27.075	10	3,367	16,835	3,276	16,380
27.085	11	3,369	16,845	3,278	16,390
27.105	12	3,373	16,865	3,282	16,410
27.115	13	3,375	16,875	3,284	16,420
27.125	14	3,377	16,885	3,286	16,430
27.135	15	3,379	16,895	3,288	16,440
27.155	16	3,383	16,915	3,292	16,460
27.165	17	3,385	16,925	3,294	16,470
27.175	18	3,387	16,935	3,296	16,480
27.185	19	3,389	16,945	3,298	16,490
27.205	20	3,393	16,965	3,302	16,510
27.215	21	3,395	16,975	3,304	16,520
27.225	22	3,397	16,985	3,306	16,530
27.255	23	3,403	17,015	3,312	16,560
27.235	24	3,399	16,995	3,308	16,540
27.245	25	3,401	17,005	3,310	16,550
27.265	26	3,405	17,025	3,314	16,570
27.275	27	3,407	17,035	3,316	16,580
27.285	28	3,409	17,045	3,318	16,590
27.295	29	3,411	17,055	3,320	16,600
27.305	30	3,413	17,065	3,322	16,610
27.315	31	3,415	17,075	3,324	16,620
27.325	32	3,417	17,085	3,326	16,630
27.325	33	3,419	17,095	3,328	16,640
27.345	34	3,421	17,105	3,330	16,650
27.355	35	3,423	17,115	3,332	16,660
27.365	36	3,425	17,125	3,334	16,670
27.375	37	3,427	17,135	3,336	16,680
27.385	38	3,429	17,145	3,338	16,690
27.395	39	3,431	17,155	3,340	16,700
27.405	40	3,433	17,165	3,342	16,710





PC-789AA (CH LED PCB)

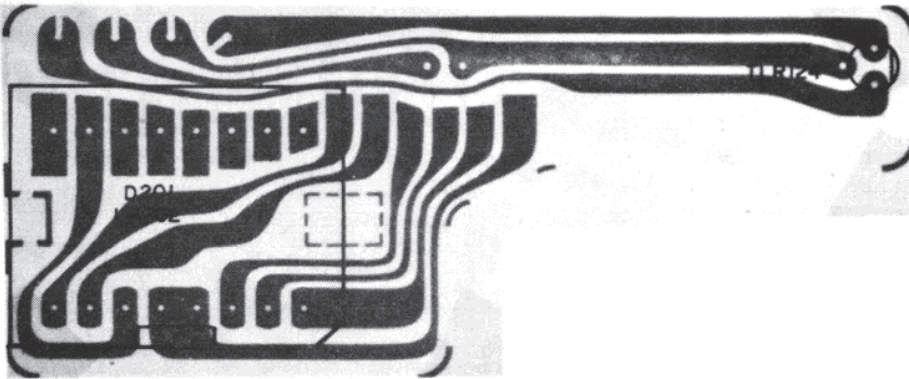

PC-969AA (CH SW PCB)

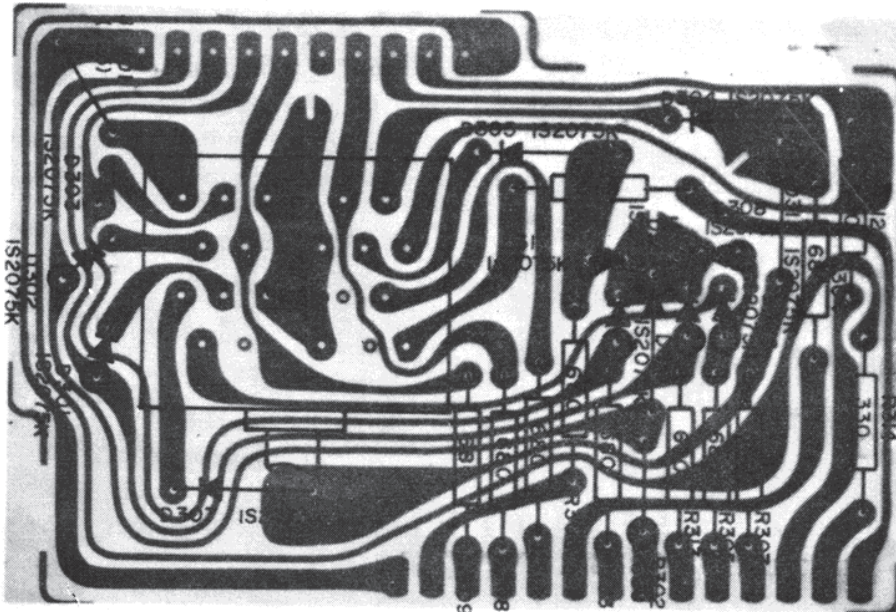

A X 711

Part No.	Generic No.	Symbol	Description
3500-108	PC - 969 AA	--	PC Board Main
3500-072	PC - 789 AA	--	PC Board LED
3500-032	PC - 266 AA	--	PC Board Mic Jack
2000-054	TA - 7222 AP	I C 1	Integrated Circuit
2000-017	TA - 7310 P	I C 2	Integrated Circuit
2000-035	TC - 9106 BP	I C 3	Integrated Circuit
2000-107	2 SK 104 - H	FET 1, 2	Field Effect Transistor
2000-218	2 SA 733 - P	TR 14, 16	Transistor
2000-291	2 SA 1015 - 0	TR 22	Transistor
2000-258	2 SC 945 A - Q	TR 6, 19, 21, 23	Transistor
2000-203	2 SC 458 - C	TR 10, 13	Transistor
2000-288	2 SC 380 TM - O	TR 15	Transistor
2000-240	ZSC 1674 - L	TR 1	Transistor
2000-213	ZSC 1675 - L	TR 2, 3, 4, 11, 12	Transistor
2000-249	2 SC 2075	TR 7	Transistor
2000-247	2 SC 2236 - O	TR 18	Transistor
2000-248	2 SC 2236 - Y	TR 17	Transistor
2000-216	2 SC 941 TM - 0	TR 9	Transistor
2000-244	2 SC 1815 - O	TR 5	Transistor
2000-303	IS 2075 - K	D 1, 2, 3, 5, 7, 8, 9, 12, 14, 16, 18, 19, 301, 302, 303, 304, 305, 306, 307, 308, 309, 310, 311, 312, 313,	Diode
2000-301	IN 60 - AM	D 4, 6	Diode
2000-320	IN 4003	D 10, 17	Diode
2000-311	RD 7.5 EB 2	D 13	Diode Zener
2000-370	RD 10 EB 1	D 15	Diode Zener
2000-344	IS 2688 - EB	D 11	Diode Vari-Cap
2000-347	TLR - 124	D 203	Diode LED
2000-306	UR - 202	D 201	Diode LED
2000-355	FLG - 12 HA	D 401	Diode LED
2200-001	LA - 029	L 1	Coil
2200-084	LA - 088	L 18	Coil
2200-081	LA - 106	L 5	Coil
2200-082	LA - 138	L 2	Coil
2200-083	LA - 165	L 15	Coil
2200-003	LA - 180	L 19	Coil
2200-004	LA - 181	L 3, 4	Coil
2200-045	LA - 198	L 18	Coil
2200-047	LA - 201	L 16	Coil
2200-048	LA - 204	L 6	Coil
2200-085	LA - 208	L 14	Coil
2200-086	LA - 276	L 7	Coil
2200-034	LC - 073	L 10	Coil
2200-020	LC - 130	L 13, 20	Coil
2200-017	LD - 033	L 11	Coil
2200-019	LD - 055	L 501, 502	Coil
2200-052	LD - 087	L 12, 50	Ferrite Bead Core
2200-101	LD - 088	L 401	Ferrite Bead Core
2200-087	LE - 206	L 9	Coil
2200-548	LE - 207	L 8	Coil
2300-001	TF - 083	T 2	Transformer AF Choke
2600-008	TF - 129	T 1	Transformer Output
1900-205	RV - 182 500 B	VR 2.5	R Semi-fixed
1900-204	RV - 182 20 KB	VR 1.3	R Semi-fixed

A X 711

Part No.	Generic NO.	Symbol	Description
1900-153	RV - 182 50 KB	VR 4	R Semi-fixed
2200-301	FL - 048	CF 1	Filter Ceramic
2200-302	FL - 066	CF 2	Filter Ceramic
3000-155	SR - 319	S 301	Switch Rotary
3000-041	SW - 275	S 401, 402, 403, 404	Switch Push
1900-130	RV - 227 1 KB	VR 401	R Variable
1900-104	RV - 320 50 KA	VR 403	R Variable
1900-144	RV - 334 50 KB	VR 402	R Variable
1900-150	RV - 343 10 KA	VR 404	R Variable
3400-235	YD - 019 (003)	--	Bush Insulation
3400-403	YD - 039	TA 7222 AP	Insulation Sheet
3400-212	YD - 041	2 SC 2075	Insulation Sheet
1100-801	YY - 047	--	Clamper Wire
2100-013	QX - 074	X 7	Crystal
3100-009	SP - 057	SP 401	Speaker
3100-013	SP - 072		Speaker (Extension)
2900-011	MT - 147	M 401	Meter
3200-028	MK - 172	--	Microphone
1100-002	JK - 068	J 501	Jack Antenna
1100-004	JK - 087	J 501	Jack Microphone
1100-021	JK - 089	J 402, 403	Jack Speaker
1100-003	Jk - 052	J 405	Receptacle AC Power
2800-001	FS - 014 (2A)	F 401	Fuse
2700-001	W - 070088	--	DC Power Cord
3300-118			Cover Top
3300-160			Cover Bottom
3300-210			Shield Plate
3300-401			Hanger Microphone
3300-558			Panel Front
1300-001		ABS Cr-1	Knob Channel
1300-002			Knob
1300-003			Knob Core Push Button
1100-202			Screw Mounting
3400-161			Nameplate Brand
1700-201			Label Serial No.
1600-004			Label Warning DC Cord
3400-616			Nameplate Control
3400-108			Optical Filter Display
1100-315			Washer Rubber
1100-702		M 3x6	Screw Pan Hd Plastic
1100-777		M 3x6	Screw Pan Hd Plastic
1100-705		M 3x8	Screw Nind Hd
1100-707		3x8	Tapping Screw Bind Hd
1100-708		3.5x8	Tapping Screw Round Hd
1100-709		5x10	Tapping Screw Round Hd
1100-725		M 3x6	Tap Tight Screw Bind Hd
1100-778		M 3x6	Tap Tight Screw Bind Hd
1100-711		3.5	Washer Lock
1100-712		5	Washer Star
1100-735		M 3	Nut Hex
1100-710		M 3	Nut Flange

A X 711

Part No.	Generic No.	Symbol	Description
1100-305			Spring Plate Knob
1100-311			Rivet AL ID Plate
1100-307			Terminal Lug, Solder
1500-009			Styrofoam Pad
1500-109			Styrofoam Pad
1500-252			Display Box
1600-193			Owners Instruction Manual
1600-201			Warranty Card
1600-501			FCC Rules Part 95 FCC